

healthcare

MIL'S,
on-site oxygen
production

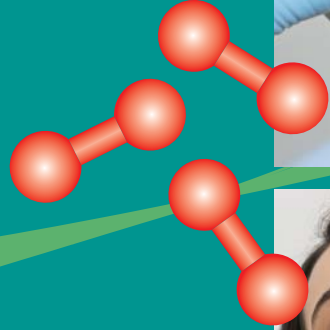

oxygen



Since 1926

Designer and manufacturer for healthcare applications	2
--	---

Medical air plants for oxygen generators

HOSPITAIR® PACK S and G S - 11 bar	4
------------------------------------	---

Air treatment devices

SEC 70X	6
---------	---

Accessories

Vertical air receivers	8
Vertical oxygen receivers	8
Pressure release lines	8
Oil-water separator	9
Hygro 2000V : hygrometry probe	10
Flowmeter for O ₂	11

Oxygen generators

PRO ₂ XY® 5 bar	12
PRO ₂ XY® 12 bar	14

Analysers

O ₂ analyser and monitoring	16
CO / CO ₂ analyser	17

Oxygen production plants

Oxygen container - composite material	18
Oxygen container - metallic material	22

Lubricated screw technology plants for filling station

AIRMIL'S G	24
------------	----

Air treatment devices

SEC F to SEC 3F	26
-----------------	----

Oxygen high pressure cylinder filling station

OX HP 3	28
OX HP 6 / OX HP 12	30
Cylinder filling skid	32

Regulation

PROCOM 2 : Control and regulation device	33
VIGIFLUID : Monitoring system for medical fluids	34
Energy monitoring	35

MIL'S : Services

Services	36
Useful formulae	38
General conditions of sale and guarantee	39

Main office



Vacuum pumps site



Machining



Design office

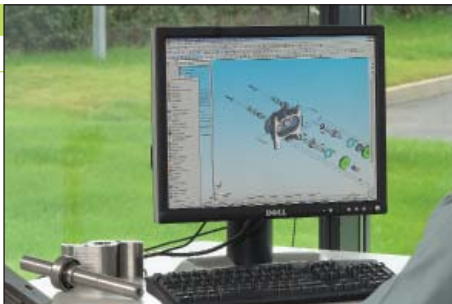

Check room



Testing room



Our company

MIL'S, French vacuum pumps manufacturer, was founded in 1926 and currently employs 90 people on two sites in the outskirts of Lyon and one sales office in the outskirts of Paris. The company operates over 15 000 sq.m of manufacturing floor space.

From design through to sale, our understanding and control of the processes involved enables us to offer a high quality product, using :

- State-of-the-art computer assisted design software
- NC-plant and equipment and several assembly facilities
- Product packaging techniques devised in-house
- A dynamic, solutions-oriented sales force
- Field service engineers and maintenance contracts for your plant and equipment
- Our customer training centre to transfer in depth knowledge of our products and their uses.

Designer and manufacturer

for healthcare applications

anaesthesia **MADE IN FRANCE**

resuscitation



emergency



neonatology

surgery



sterilisation

Our products

From simple vacuum pump or compressor to fully integrated vacuum, oxygen and medicinal air systems, MIL'S proposes a wide range of possibilities developed for your specific applications.

We have been specialised in medical vacuum and air for many years and can boast a satisfied customer base, worldwide of over 3 500 healthcare facilities operating.

Our medical range, meeting 2007/47 directive, carries the CE-mark.

HOSPITAIR® PACK S - 11 bar G S - 11 bar

screw compressors

- Compressed air plant high efficiency with lubricated screw compressor to supply oxygen generator
- IE3 electrical motor for intensive use
- Easy installation using quick connectors
- Compact design
- Adsorption air dryer and air treatment systems SEC 70X type
- Medicinal air quality
- Simplified setting



Characteristics per air production assembly

HOSPITAIR® PACK S	Power kW 50 Hz	Flow rate * - 50 Hz m ³ . h ⁻¹		Air dryer type	Noise level dB(A)**	Weight kg	Air plant for the PRO ₂ XY generator
		Compressor	Treatment outlet				
MVA8	7.5	60	53	AD5065OX	64	260	OX 3 and OX 3 B
MVB12	11	100	88	AD5130OX	64	370	OX 5 and OX 5 B
MVB16	15	126	110	AD5130OX	65	380	OX 7 and OX 7 B
MVC19	18,5	179	157	AD5195OX	67	575	OX 13 and OX 13 B
MVC23	22	210	184	AD5195OX	69	595	

HOSPITAIR® G S

MVD31	30	269	236	AD5325OX	69	1060	
MVE38	37	336	295	AD5325OX	70	1400	
MVE46	45	411	361	AD5455OX	71	1500	OX 26 and OX 26 B

* Flow rates further to ISO 1217 : 1996 - C Annex

** Noise level further to PN8 NTC 2.3, measured at 1 m in a free area.

Process sequence

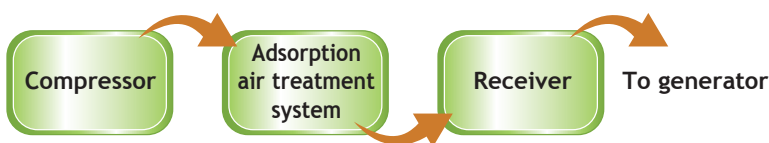

Standard power supplies

- 3-phase, 400V+N / 50Hz
- Other tensions on request



Range complying with
97/23/CE directive



Range complying with
2007/47/CE directive

Compressed air plant high efficiency for oxygen generators

Dimensions (mm)

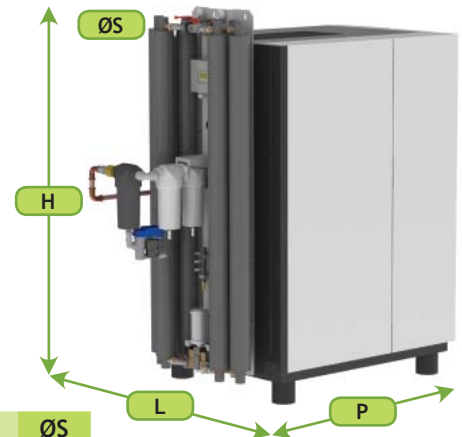
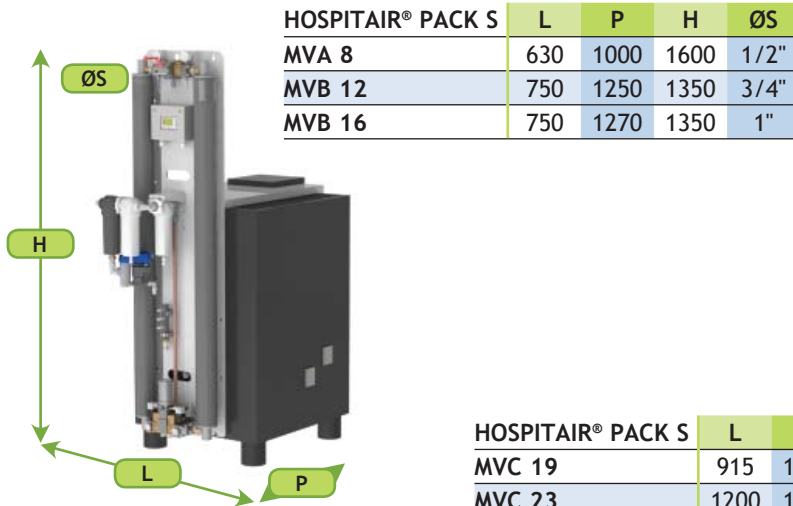

SEC 70X	P
AD 5325OX	560
AD 5455OX	700



HOSPITAIR® G S	L	P	H	ØS
MVD 31	1460	900	1530	1"1/4
MVE 38	1590	1030	1700	1"1/2
MVE 46	1590	1030	1700	1"1/2

Plant references

	MVA 8	MVB 12	MVB 16	MVC 19	MVC 23	MVD 31	MVE 38	MVE 46
Air treatment system	CY20	CY20	CY20	CY30	CY30	PF396	PF396	PF396
SEC 70X type included	PF72	PF109	PF109	PF217	PF217	SUB396	SUB396	SUB396
	SUB72	SUB109	SUB109	SUB217	SUB217	AD5325OX	AD5325OX	AD5455OX
	AD5065OX	AD5130OX	AD5130OX	AD5195OX	AD5195OX			
HOSPITAIR® PACK S or G S	824013	824014	824015	824016	824017	824018	824019	824020
Air hygrometry sensor	(1 sensor for single, duplex or triplex lines)						822284	
Equipped air receiver	1 x 500 litres		1 x 1000 litres			1 x 1500 litres		
11 bar *	1 x 722278		1 x 722279			1 x 721121		

* equipment : a safety valve, a pressure gauge, a drain valve and two valves (inlet / outlet)

Optional accessory references

Oil separator for 100% running	OWAMAT 10 (<96 m ³ /h) 359423	OWAMAT 11 (<192 m ³ /h) 362859	OWAMAT 12 (<438 m ³ /h) 362860
-----------------------------------	---	--	--

Specifications are subject to be changed without notice.

Air treatment devices

Air quality codification according to ISO 8573-1 standard

The ISO 8573-1 Standard defines air quality thanks to a codification based on residual contaminants classes:

- Solid contaminants classes, from 0 to 7
- Water classes, from 0 to 9
- Oil classes (droplets, aerosols and vapours), from 0 to 4

Classes are defined by a number. The higher the number, the higher the quantity of residual contaminants concerned.

ISO 8573-1 Class	1 st number						2 nd number	3 rd number
	Solid particles / dust						Humidity	Total oil content
	Maxi particle quantity per m ³ Particles with d(μm)						Dew point	mg/m ³
	≤ 0,1	0,1 < d ≤ 0,5	0,5 < d ≤ 1,0	1,0 < d ≤ 5,0	μm	mg/m ³	(x = liquid water content g/m ³)	
1	100	1	0				≤ -70° C	≤ 0,01
2	100 000	1 000	10				≤ -40° C	≤ 0,1
3		10 000	500				≤ -20° C	≤ 1,0
4			1 000				≤ +3° C	≤ 5,0
5			20 000				≤ +7° C	
6			100 000	≤ 5	≤ 5		≤ +10° C	
7			100 000	≤ 40	≤ 10		x ≤ 0,5	
8							0,5 < x ≤ 5,0	
9							5,0 < x ≤ 10,0	

A example : Medicinal air : quality class air **1 1 1**

B example : Compressed air for general use : quality class air **2 4 3**

Quality requirements of oxygen (93 per cent) in compliance with the European Pharmacopoeia Oxygen 93

- | | |
|--|-------------------------|
| a) Oxygen content | 93% ± 3% |
| b) Oil concentration | ≤ 0.1 mg/m ³ |
| c) Carbon monoxide concentration | ≤ 5 ppm V/V |
| d) Carbon dioxide concentration | ≤ 300 ppm V/V |
| e) Water vapor concentration | ≤ 67 ppm V/V |
| f) Sulphur dioxide concentration | ≤ 1 ppm V/V |
| g) Nitric oxides concentration (NO + NO ₂) | ≤ 2 ppm V/V |

SEC 70X

Air treatment by filtration and drying by adsorption

- Fixed on the Hospitair® PACK S
- Dew point at -70°C for delivery air
- 1, 1, 1 air quality class according to NF ISO 8573-1 standard
- Permissible maximum pressure: 16 bar
- Air dryer with expendable tubes
- Simple and easy maintenance

Filter types

- **CY:** Cyclonic filtration for condensate separation, oil and water in liquid phase 99 % efficiency. Electronic drain fitted below.
- **PF:** 1 µm micronic filtration to separate oil drops and solid particles (> 1 µm).
The residual oil aerosol is 0.5 mg/m³ at 21°C.
99.9% efficiency.
- **SUB:** 0.01 µm submicronic filter to remove particles (> 0.01 µm) and oil and water aerosols.
The residual oil aerosol is 0.01 mg/m³ at 21°C.
99.9% efficiency.
- **OX tube:** Dryer tube with molecular sieve to remove H₂O, CO₂, NO_x and odours.
- **PAROX :** Particles or bacterial filter to remove solid particles bigger than 0.01 µm.



Process sequence



Schedule for flow rate corrections according to the operation pressure							Schedule for flow rate corrections according to inlet temperature °C												
bar	7	8	10	12	14	16	Inlet temperature °C												
coeff.P	0.84	0.89	1	1.1	1.18	1.26	+25	+30	+35	+40	+45	+50	T coefficient for dew point at -45°C in reduced air	1.25	1.15	1	0.85	0.62	0.5

Percentage of regeneration gas taken from the inlet air flow rate according to the pressure, the air temperature and the expected dew point																			
Percentage of taken air according to the inlet temperature and the operating pressure																			
Expected dew point at reduced pressure	Inlet temperature °C	+25			+30			+35 standard			+40			+45			+50		
		7	10	15	7	10	15	7	10	15	7	10	15	7	10	15	7	10	15
< -25°C	Percentage	11	8	6	11	8	6	14	10	7	18	13	9	23	17	12	29	21	15
< -40°C	Percentage	12	9	7	12	9	7	15	11	8	19	14	10	24	18	13	30	22	16
< -60°C	Percentage	20	14	11	20	14	11	23	16	12	27	19	14	31	23	17	38	27	20

Device fit to 97/23/CE pressure directive - with dessicant - 230V / 50-60Hz power supply

Specifications are subject to be changed without notice.

Vertical air receivers

- Vertical air receiver equipped with a safety valve, a pressure gauge, a drain valve and two valves (inlet / outlet).

References

Vertical air receivers	500 litres	1000 litres	1500 litres
Working pressure	11 bar	12 bar	12 bar
Reference	722278	722279	721121

Dimensions (mm)

Air receiver	Ø	A	B	C	E	F
500 litres	600	2081	1655	--	785	173
1000 litres	800	2350	1680	1480	740	150

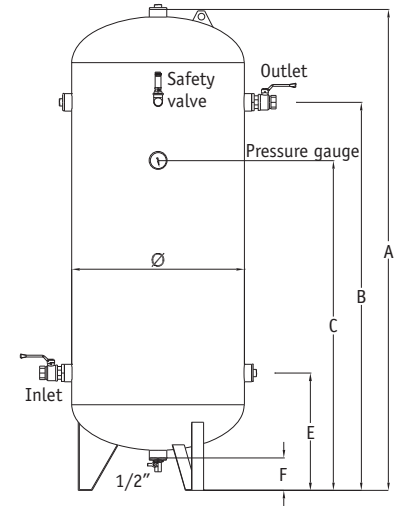

Vertical oxygen receivers

- Vertical oxygen receiver equipped with an isolating valve, an analysis connection for the paramagnetic sensor and information connections for sensors.
- The oxygen storage receiver is necessary with the PRO₂XY 12 bar type generator.

References

Vertical oxygen receivers	500 litres	1000 litres	1000 litres*
Working pressure	12 bar	12 bar	12 bar
Reference	722291	722293	723981

* for PRO₂XY OX26B

Dimensions (mm)

Oxygen receiver 12 bar	A	B	C
500 litres	825	890	1850
1000 litres	985	1090	2230
1000 litres (for PRO ₂ XY OX26B)	940	980	2230

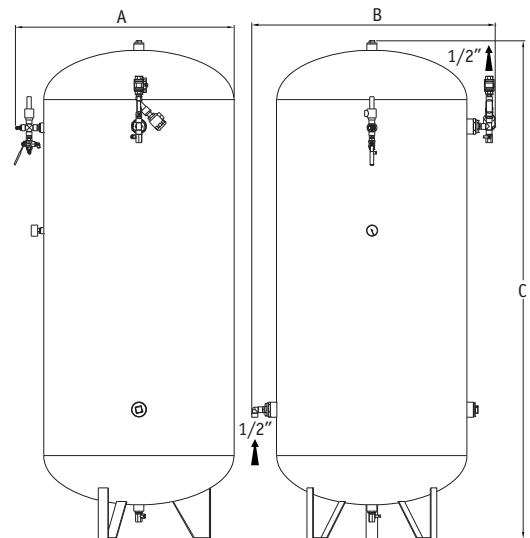

Range complying with 97/23/CE directive

Pressure release lines 9 bar

for single line generator
PRO₂XY - 12 bar
BP300 + PAROX 36

for multi-line generators
PRO₂XY - 12 bar
2 x (BP300 + PAROX36)

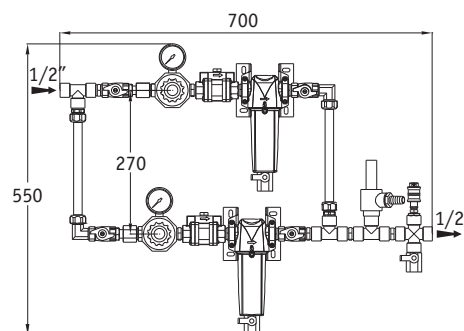
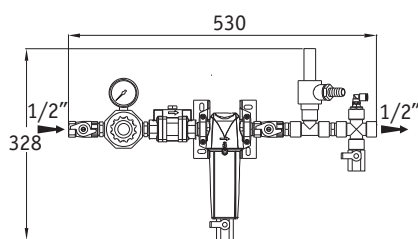

Dimensions (mm)

Specifications are subject to be changed without notice.

Oil-water separator for clean effluent discharge

- Oil gravimetric condensate separation
- Oil less effluent discharge
- Reduced maintenance



Choice according to the flow rate

Standard Type	screw with oil injection from 7.5 to 15 bar (for loading at 100%) in m ³ .h ⁻¹
OWAMAT 10	96
OWAMAT 11	192
OWAMAT 12	438
OWAMAT 14	852
OWAMAT 15	1758

References

	OWAMAT 10	OWAMAT 11	OWAMAT 12	OWAMAT 14	OWAMAT 15
Complete standard type	359423	362859	362860	362861	362862

Accessory and option references

	OWAMAT 10	OWAMAT 11	OWAMAT 12	OWAMAT 14	OWAMAT 15
Filter for standard type	362721	362478	362479	362480	362481
Turbidity set (1 test tube for sampling and 1 test tube for reference)	357578				
Oil level alarm indicator	357579				
Heater		362863		362864	

Dimensions (mm)

K : condensate inlet - W : water outlet
P : water test - O : oil outlet

Type	A	B	C	F	G	H
OWAMAT 12	719	350	397	320	340	200
OWAMAT 14	892	410	461	420	460	240
OWAMAT 15	1118	520	573	505	550	270

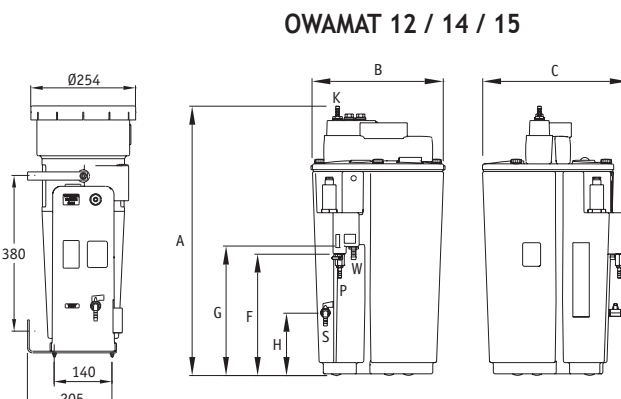
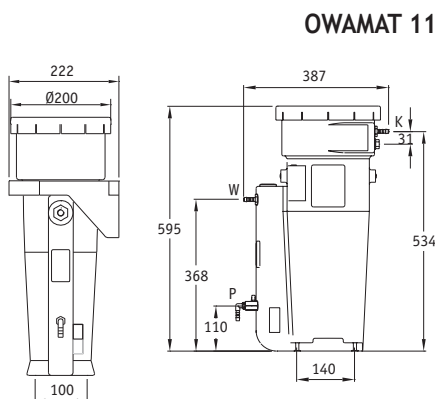
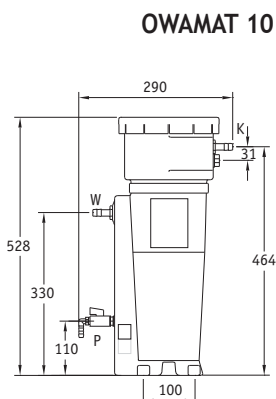

- Continuous measurement of gas dew point
- Dew point measurement range: -80°C to +20°C at atmospheric pressure
- Great stability over time even with a low dew point
- Polymeric thin-layer sensor with automatic calibration
- Fast response time
- Insensitive towards condensation, particle contamination, oil vapours and most of chemicals
- Alarm on dry contact adjustable on the whole measurement range (250V - 4A maxi)
- Available output : 4 - 20 mA
- The probe included in the cabinet can be delivered separately
- Power supply 200/260V - 50/60 Hz

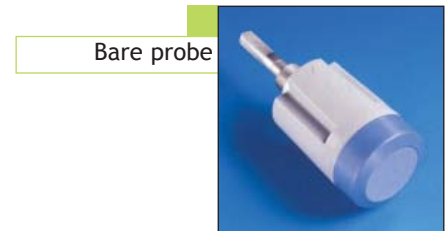

Bare probe

Dew point temperature

- | | |
|---|--|
| • Measurement range | -80°C...+20°C |
| • Dew point precision up to -60°C | ± 2°C |
| • Response time of 63% (90%) with a gas temperature at 20°C, a flow rate higher than 1l/min and a pressure of 1 bar | -60 → -20°C Td 5s (10 s)
-20 → -60°C Td 45 s (10 min) |

Operating conditions

- | | |
|---------------------|-------------|
| • Temperature | 0...+60°C |
| • Relative humidity | 0...100% HR |
| • Pressure | 0...20 bar |
| • Sample flow rate | no effect |

Probe characteristics

- | | |
|---|---------------------------------|
| • Analogical output | 4...20 mA |
| • Operating voltage | 17-35 V DC
20/28 V AC |
| • Sink current at 24 V DC | 220 mA max. |
| • External charge for analogical output | 500 Ω max. |
| • Sensor protection | Sintered stainless steel filter |
| • Protection level | PF 65 (NEMA 4) |
| • Storage temperature | -40...+70°C |
| • Delivered with 1,5 meter-long cable | |

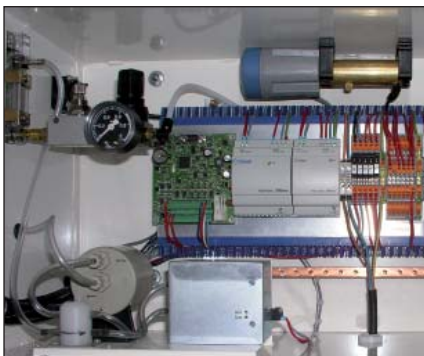

Dimensions (mm)

Probe with sampling probe carrier

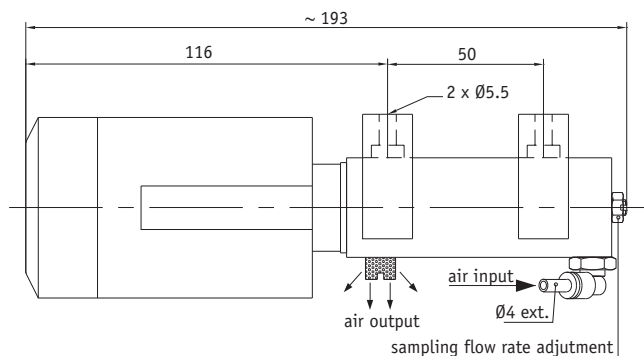

References

Air hygrometry monitoring
O₂ hygrometry monitoring

822284
823735

Flowmeter for medicinal O₂

- Monitoring of O₂ consumption on the primary and secondary network.
- On the flowmeter display: instantaneous consumption or accumulated consumption.



- Connection to PROCOM 2 with:
 - instantaneous consumption display,
 - Average flow + accumulated consumption for one period,
 - Average flow + accumulated consumption for the current month,
 - Average flow + accumulated consumption for the previous month,
 - overhead alarm management.
- Principle of measure: calorimetry
- Operating pressure: 10 bar.
- Permissible pressure: 16 bar.
- Operating temperature: -10°C / +60°C.
- Output signal 4-20 mA.
- Power supply 24 Vdc.
- Accuracy: ± 1,5% of measured value
± 0,05% of full scale

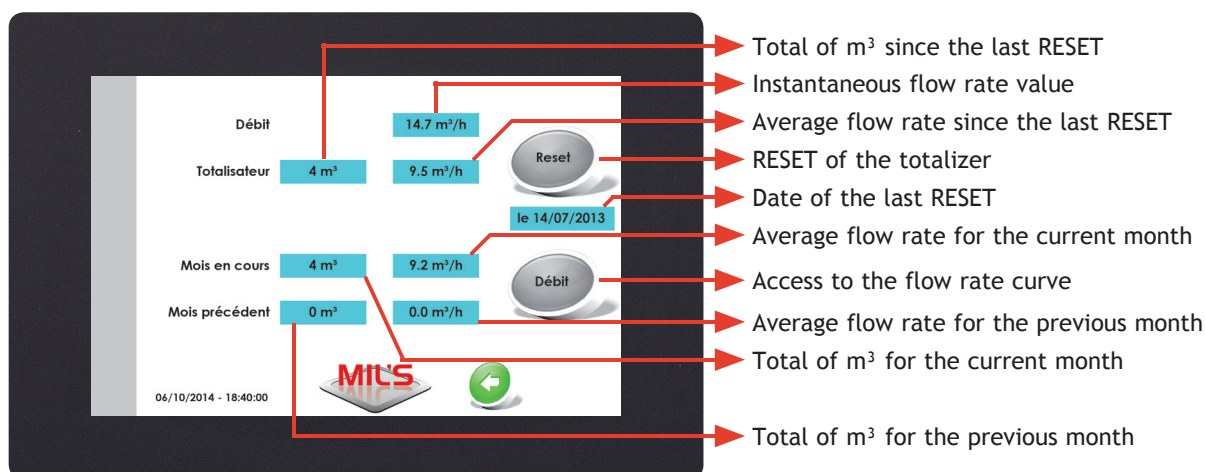

Dimensions (mm)

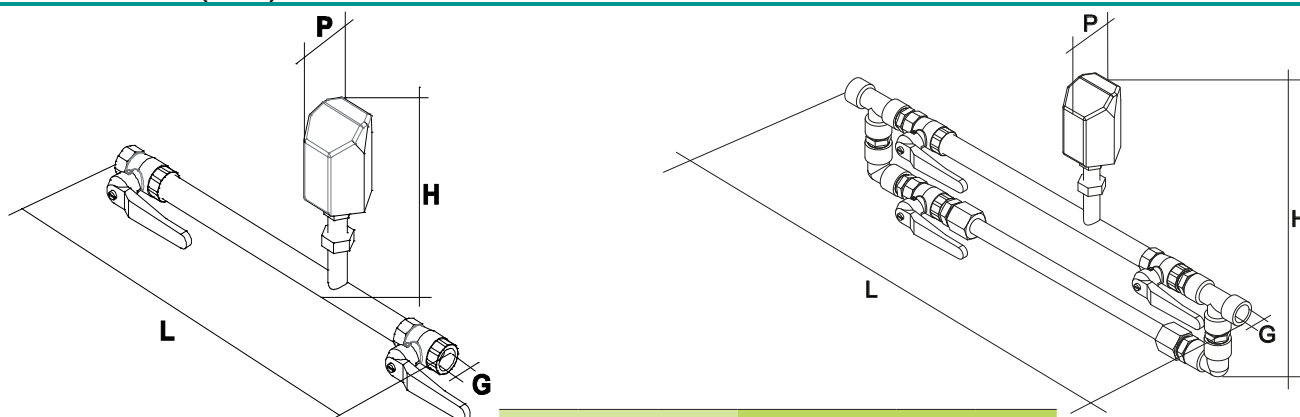

Simple mounting			By-pass mounting			
L	P	H	L	P	H	G
376	69	180	534	69	260	1/2"

References

	Flow rate range m ³ .h ⁻¹	O ₂	
		Simple mounting	By-pass mounting
DM 090 OX	0,2 to 90 m ³ /h	624682	624683

PRO₂XY® - 5 bar

- Purity maxi. > 95%
- Oxygen available upon request or continuously
- Economic oxygen production
- Simple and reliable production technology
- Constant flow and pressure of oxygen no matter the consumption (MIL'S patent)
- Pressure at 5 bar for single stage network pressure
- PROCOM 2 control device (see page 32)
- Very compact system
- Low maintenance requirements
- Complies with ISO 10083, European Pharmacopoeia Oxygen 93 and NF S95 175



Characteristics

- Flow from 4 to 35 Nm³/h @ 93%
- Oxygen exhaust pressure : 5 bar
- O₂ measurement by heated and regulated paramagnetic sensor and with back pressure regulator
- CO / CO₂ infrared monitoring (optional)
- Dew point monitoring of O₂ (optional)
- Ambient O₂ monitoring (optional)
- Power consumption monitoring (optional)
- Working temperature from 5 °C to 45 °C
- Continuous running 24 hours (7/7)
- Power supply : 1-phase 230V - 50 / 60 Hz (100W)

PRO ₂ XY®	OX 3	OX 5	OX 7	OX 9	OX 13	OX 16	OX 26	OX 32
Flow @ 95% (Nm ³ /h)	3	4.5	7	9	13	16	26	32
Flow @ 93% (Nm ³ /h)	4	5	7.7	9.9	14.3	17.6	28.6	35.2
Air inlet pressure	6.5 bar							
Oxygen exhaust pressure	between 4.5 and 5.5 bar							
Required air flow (Nm ³ /h)	40	60	93	119	150	184	300	368
Oxygen storage tank volume @ 5 bar	200 liters ▪		500 liters ▪				1000 liters ▪	
Weight (kg)	290	440	640	900		1455		
Required air plant in 11 bar HOSPITAIR® PACK S or G S	MVA 8	MVB 12	MVB 16	MVC 19	MVC23	MVE 46		

▪ Storage tank included : capacity of 200 or 500 litres mounted on the generator, capacity of 1000 litres delivered separately

Process sequence

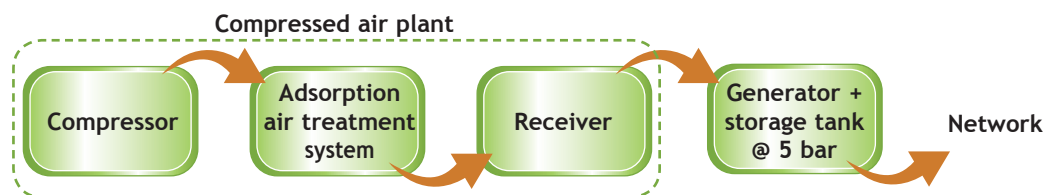

Air is a mixture of different gases with a proportion of 78% nitrogen, 21% oxygen, and 1% argon and others gases. Oxygen Generator separates oxygen from compressed air through a pressure swing adsorption (PSA) process. The synthetic zeolite of the molecular sieve adsorbs nitrogen and concentrates the oxygen up to a level of 95%. Furthermore, the oxygen flow is kept constant thanks to the two cylinders filled with molecular sieve (synthetic zeolite).



Range complying with 2007/47/CE directive



Range complying with 97/23/CE directive

Dimensions (mm)

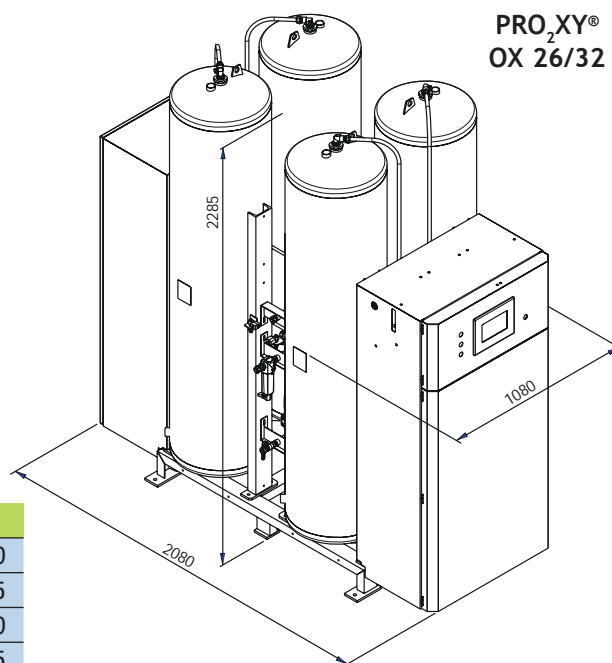
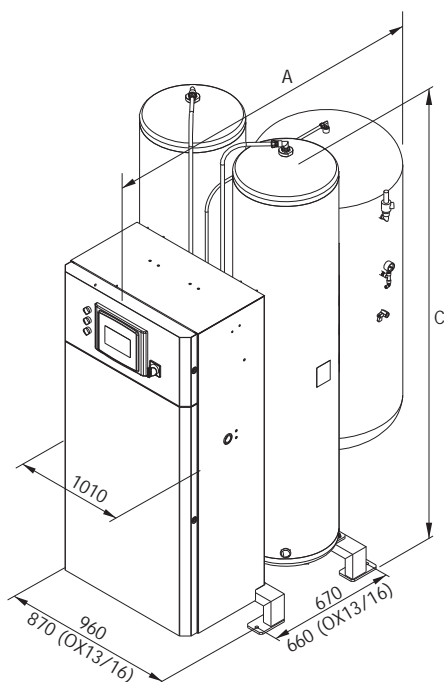

	A	C
OX 3	1210	1890
OX 5	1240	2015
OX 7/9	1480	2140
OX 13/16	1580	2295

Configuration

Measurements	O ₂	O ₂ network pressure	H ₂ O O ₂	CO ₂	CO	H ₂ O air	Air pressure	Ambient O ₂	Power consumption
Single line	✓	✓	●	●	●	●	✓	●	●
Multi-line N° 1	✓	✓	●	●	●	●	✓	●	●
Multi-line N° 2	✓							●	●
Multi-line N° 3	✓							●	●

✓ standard equipment ● optional

PRO₂XY® - 5 bar - references

		OX 3	OX 5	OX 7	OX 9	OX 13	OX 16	OX 26	OX 32
Generator	Single line	920423	920424	920425	924629	921487	924633	923854	924637
Generator multi-line	Line N° 1	922311	922312	922313	924630	922314	924634	923855	924638
	Line N° 2	922832	922833	922834	924631	922835	924635	923856	924639
	Line N° 3	922948	922949	922950	924632	922951	924636	923857	924640
1 Paramagnetic O ₂ sensor *		Foreseen 1 per generator				622272			

* Electrochemical oxygen analyser: consult us.

Optional accessory references

PROCOM 2 extension for generator single line or line N° 1 (when an option is selected)	363171
2 Manual CO / CO ₂ infrared analyser	724383
Automatic CO / CO ₂ infrared analyser	724385
3 Air hygrometry monitoring	822284
O ₂ hygrometry monitoring	823735
4 Wall-mounting analyser: O ₂ / ambient air	622709
Power consumption monitoring	see page 34
Portable ambient oxygen analyser	622765
Uninterruptible power supply (1 per generator)	624030

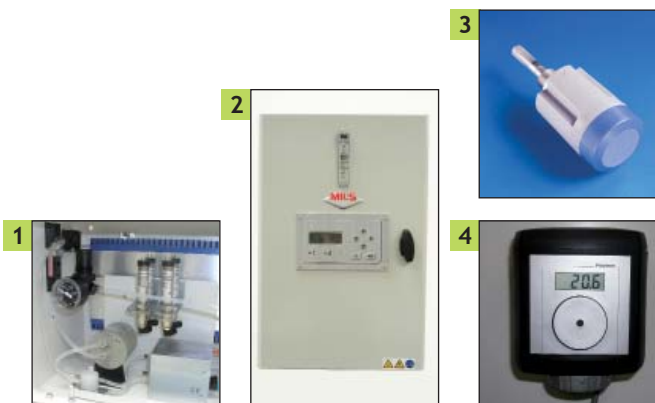

Specifications are subject to be changed without notice.

PRO₂XY[®] - 12 bar

- Purity maxi. > 95%
- Oxygen available upon request or continuously
- Economic oxygen production
- Simple and reliable production technology
- Constant flow and pressure of oxygen no matter the consumption (MIL'S patent)
- Pressure at 12 bar (14 bar maxi) for double stage network pressure using compression by an oil-free booster
- PROCOM 2 control device (see page 32)
- Very compact system
- Low maintenance requirements
- Complies with ISO 10083, European Pharmacopoeia Oxygen 93 and NF S95 175



Characteristics

- Flow from 4 to 35 Nm³/h @ 93%
- O₂ storage pressure: 12 bar (14 bar maxi) / 9 bar: after pressure release on network
- O₂ measurement by heated and regulated paramagnetic sensor and with back pressure regulator
- CO / CO₂ infrared monitoring (optional)
- Dew point monitoring of O₂ (optional) and of air (optional)
- Ambient O₂ monitoring (optional)
- Power consumption monitoring (optional)
- Working temperature from 5°C to 45°C
- Continuous running 24 hours (7/7)
- Power supply: 3-phase 400V + N + G - 50/60 Hz

PRO ₂ XY [®] with booster	OX 3 B	OX 5 B	OX 7 B	OX 9 B	OX 13 B	OX 16 B	OX 26 B	OX 32 B
Flow @ 95% (Nm ³ /h)	3	4.5	7	9	13	16	26	32
Flow @ 93% (Nm ³ /h)	4	5	7.7	9.9	14.3	17.6	28.6	35.2
Air inlet pressure	6.5 bar							
Oxygen storage pressure	12 bar (14 bar maxi)							
Required air flow (Nm ³ /h)	40	60	93	119	150	184	300	368
Oxygen storage tank volume @ 5 bar	200 liters ▪		500 liters ▪			1000 liters ▪		
Oxygen storage tank volume @ 12 bar	500 liters		1000 liters			1000 liters		
Electrical power (W)	700		1650			2350		
Weight (kg)	320	470	670	930		1515		
Required air plant in 11 bar HOSPITAIR [®] PACK S or G S	MVA 8	MVB 12	MVB 16	MVC 19	MVC23	MVE 46		

• Storage tank @ 5 bar included : capacity of 200 or 500 litres mounted on the generator, capacity of 1000 litres delivered separately

Process sequence

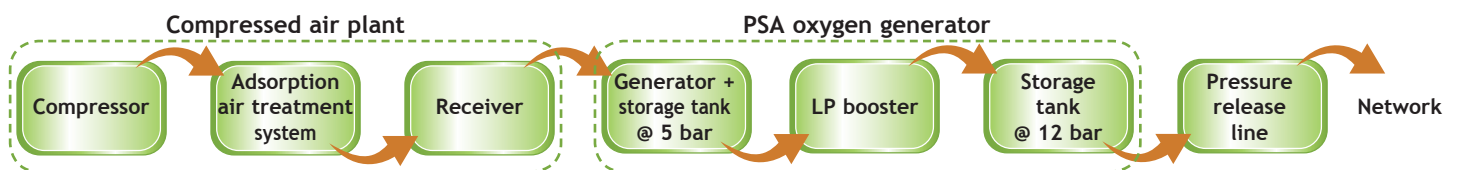

Air is a mixture of different gases with a proportion of 78% nitrogen, 21% oxygen, and 1% argon and others gases. Oxygen Generator separates oxygen from compressed air through a pressure swing adsorption (PSA) process. The synthetic zeolite of the molecular sieve adsorbs nitrogen and concentrates the oxygen up to a level of 95%. Furthermore, the oxygen flow is kept constant thanks to the two cylinders filled with molecular sieve (synthetic zeolite).



Range complying with 2007/47/CE directive



Range complying with 97/23/CE directive

Dimensions (mm)

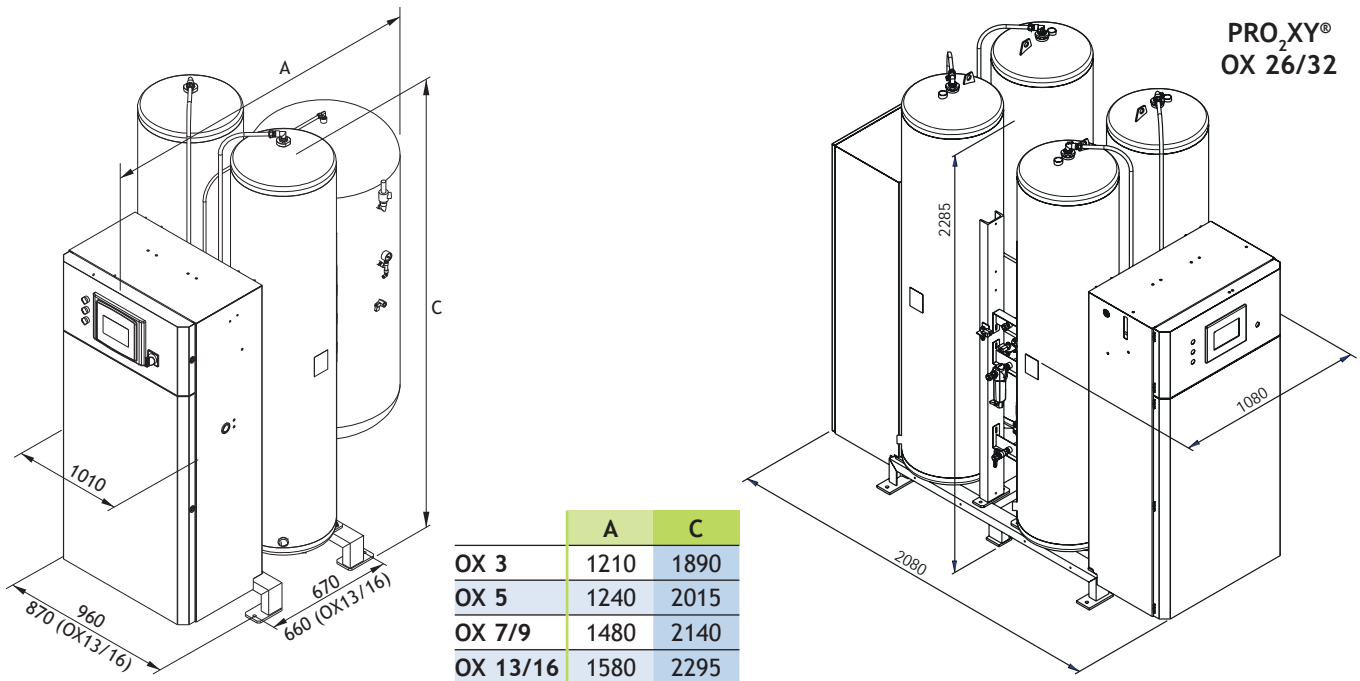

Configuration

Measurements	O ₂	O ₂ network pressure	H ₂ O O ₂	CO ₂	CO	H ₂ O air	Air pressure	Ambient O ₂	Power consumption
Single line	✓	✓	●	●	●	●	✓	●	●
Multi-line N° 1	✓	✓	●	●	●	●	✓	●	●
Multi-line N° 2	✓							●	●
Multi-line N° 3	✓							●	●

✓ standard equipment ● optional

PRO₂XY® - 12 bar - references

		OX 3 B	OX 5 B	OX 7 B	OX 9 B	OX 13 B	OX 16 B	OX 26 B	OX 32 B
Generator	Single line	924431	924435	924439	924641	924443	924645	924447	924649
Generator multi-line	Line N° 1	924432	924436	924440	924642	924444	924646	924448	924650
	Line N° 2	924433	924437	924441	924643	924445	924647	924449	924651
	Line N° 3	924434	924438	924442	924644	924446	924648	924450	924652
Oxygen storage tank @ 12 bar: 1 per line		500l.	722291	1000 liters		722293		1000l.	723981
Pressure release line @ 9 bar	Single line	BP300 + PAROX36						722294	
	Multi-line	2 x (BP300 + PAROX36)						722295	
1 Paramagnetic O ₂ sensor *		Foreseen 1 per generator						622272	

* Electrochemical oxygen analyser: consult us.

Optional accessory references

PROCOM 2 extension for generator single line or line N° 1 (when an option is selected)	363171
2 Manual CO / CO ₂ infrared analyser	724383
Automatic CO / CO ₂ infrared analyser	724385
3 Air hygrometry monitoring	822284
O ₂ hygrometry monitoring	823735
4 Wall-mounting analyser: O ₂ / ambient air	622709
Power consumption monitoring	see page 34
Portable ambient oxygen analyser	622765
Uninterruptible power supply (1 per generator)	624030

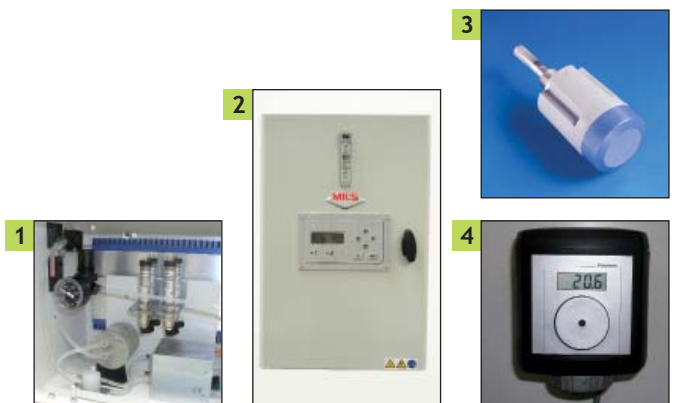

Specifications are subject to be changed without notice.

O₂ analyser and monitoring

Paramagnetic oxygen analyser 80 - 100%

Range 80 - 100%

- Monitoring of oxygen concentration of generator.
- Oxygen has a relatively high magnetic susceptibility as compared to other gases. The paramagnetic oxygen sensor consists of two glass spheres filled with nitrogen gas, they are suspended with strong metal. The spheres are kept in balance in an inhomogeneous magnetic field. The oxygen molecules are attracted to the stronger of the two magnetic fields. This causes a displacement of the dumbbell which results in the dumbbell rotating. When oxygen molecules having a large magnetic susceptibility flow there, the molecules are pulled toward the stronger magnetic field zone and the spheres are moved away from the zone. The resulting deviation of the spheres is detected with the light source, reflecting mirror and light receiving element, and a current is flowed through the feedback loop to control so that the spheres can return to the initial balanced state. The current required to maintain the dumbbell in its normal state is directly proportional to the partial pressure of oxygen and is represented electronically in percent oxygen. The paramagnetic cell is thermostated and is equipped with a barometric compensator in order to carry out measurement without impact of the room temperature nor of the atmospheric pressure.

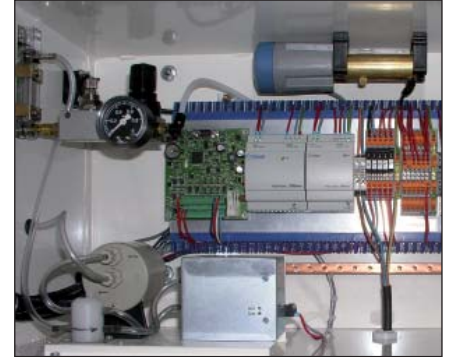

Paramagnetic oxygen analyser (foresee one per generator)

622272

Electrochemical oxygen analyser 0 - 100%

Range 0 - 100%

- Monitoring of oxygen concentration of generator.
- The measuring gas diffuses through a membrane to a thin layer of electrolyte. At the cathode the oxygen reduces. The free flowing electrons are drifting to the Anode. This generates an electrical current which is direct proportional to the oxygen concentration of the measuring gas.



Electrochemical oxygen analyser (foresee one per generator)

623931

Electrochemical oxygen analyser 0 - 25%

Range 0 - 25%

- Monitoring of ambient oxygen concentration
- The measuring gas diffuses through a membrane to a thin layer of electrolyte. At the cathode the oxygen reduces. The free flowing electrons are drifting to the Anode. This generates an electrical current which is direct proportional to the oxygen concentration of the measuring gas.
- Connected to the PROCOM 2, high and low ambient oxygen alarm are managed. The calorics exhaust fan is also controlled according to the ambient oxygen concentration.



Electrochemical oxygen analyser

622709

Specifications are subject to be changed without notice.

CO/CO₂ infrared analyser

for quality control of medicinal air and oxygen

- The CO/CO₂ analyser was designed to give a mean to ensure the conformity of medicinal air with French standard NF 90 140 and the conformity of oxygen with the European Pharmacopoeia Oxygen 93 per cent.
- Studies in Universities and Laboratories have shown that CO₂ was the first of the air pollutant breaking through the molecular mesh used to purify the ambient air for medicinal use. Continuous measurement of CO₂ ensures the quality of the air or of the oxygen delivered in hospital.
- CO, which is not stopped by the molecular mesh, has to be measured to ensure a good operation of oxidation module installed before the air purifier.



Principle

- CO and CO₂ measurement is based on infrared photometry.

Outstanding features

- Verification of the manual calibration every 3 to 6 months or automatic calibration with 2 reference gas (one for zero and the second for the scale).
- Reduced maintenance.
- Wall mounted cabinet easy to install.
- Direct connection onto medicinal air line or oxygen line.

Main technical specifications

- **Measuring ranges** 0 - 50 ppm for CO / 0 - 1000 ppm for CO₂
- **Accuracy** zero-point drift < 2% per week
span (sensitivity) drift < 0.5% per week
- **Measurement** Continuous measurement of CO and CO₂ on dry air
- **Air flow** from 0.2 to 1.5 l/min
- **Temperature** 0 to +50°C
- **Output signal** 4-20 mA → CO / 4-20 mA → CO₂
(for remote control on PROCOM 2 or other system)
- **Power supply** 230V AC - 50 Hz - 1 A
- **Cabinet construction** metal housing 700 x 500 x 250 mm (H x W x D)



References

	Medicinal air	Oxygen
Infrared analyzer CO - manual calibration	724115	724382
Infrared analyzer CO / CO ₂ - manual calibration	724097	724383
Infrared analyzer CO - automatic calibration	724131	724384
Infrared analyzer CO / CO ₂ - automatic calibration	724132	724385

OXYGEN CONTAINER

Composite material

1 air plant / 1 PRO₂XY[®] generator

- Two compartments : one for air supply and one for oxygen production
- O₂ measurement by heated and regulated paramagnetic sensor and with back pressure regulator
- Air hygrometry monitoring is included in the container
- Compact design
- Simplified setting
- Ready-to-run plants
- Complies with ISO 10083 and NF S95 175



Cabin made of composites sandwich panels for good insulation

Process sequence @ 5 bar



Range complying with 2007/47/CE directive



Range complying with 97/23/CE directive

Process sequence @ 12 bar



Dimensions (mm)

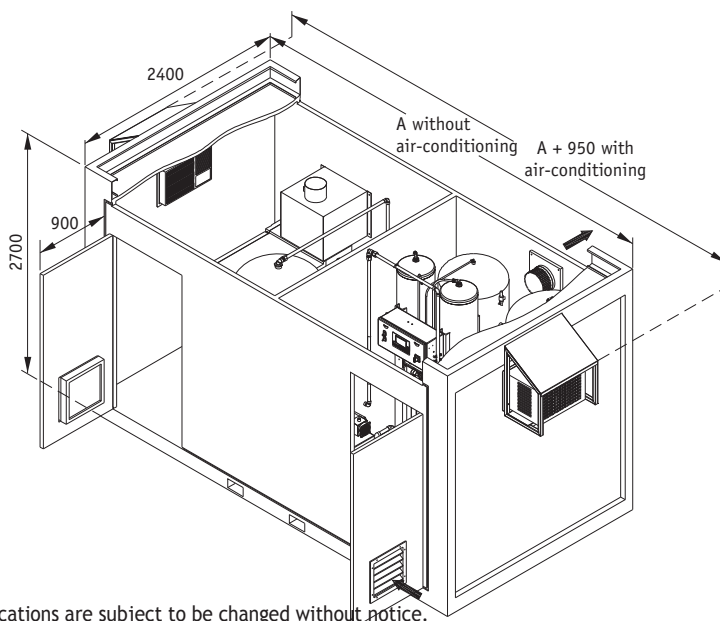

	A	Weight (kg)
MVA 8 + OX 3	3500	2500
MVA 8 + OX 3B	4000	2700
MVB 12 + OX 5	3500	2500
MVB 12 + OX 5B	4000	2700
MVB 16 + OX 7	4000	3000
MVB 16 + OX 7B	4700	3200
MVC 19 + OX 13	5000	4000
MVC 19 + OX 13B	5000	4200

Standard power supplies

- 3-phase, 400V / 50Hz
- Other tensions on request

PSA oxygen production plants

Configuration

Measurements	O ₂	O ₂ network pressure	H ₂ O O ₂	CO ₂	CO	H ₂ O air	Air pressure	Ambient O ₂	Power consumption
Single line	✓	✓	●	●	●	●	✓	●	●
Multi-line N° 1	✓	✓	●	●	●	●	✓	●	●
Multi-line N° 2	✓							●	●
Multi-line N° 3	✓							●	●

✓ standard equipment ● optional

Plant references

AIR/O ₂ Container SINGLE LINE	MVA 8 + OX 3	MVA 8 + OX 3B	MVB 12 + OX 5	MVB 12 + OX 5B	MVB 16 + OX 7	MVB 16 + OX 7B	MVC 19 + OX 13	MVC 19 + OX 13B
1 compressor	MVA 8	MVA 8	MVB 12	MVB 12	MVB 16	MVB 16	MVC 19	MVC 19
1 air treatment system SEC 70X	CY20 PF72 SUB72 AD5065OX	CY20 PF72 SUB72 AD5065OX	CY20 PF109 SUB109 AD5130OX	CY20 PF109 SUB109 AD5130OX	CY20 PF109 SUB109 AD5130OX	CY20 PF109 SUB109 AD5130OX	CY30 PF217 SUB217 AD5195OX	CY30 PF217 SUB217 AD5195OX
1 air receiver	500 litres				1000 litres			
1 generator	OX 3	OX 3B	OX 5	OX 5B	OX 7	OX 7B	OX 13	OX 13B
1 x O ₂ storage tank volume @ 5 bar	200 litres				500 litres			
1 x O ₂ storage tank volume @ 12 bar	---	500 litres	---	500 litres	---	1000 litres	---	1000 litres
Without air-conditioning	922693	922694	922695	922696	922697	922698	922699	922700
With air-conditioning	922842	922843	922844	922845	922846	922847	922848	922849
AIR/O ₂ Container MULTI-LINE	MVA 8 + OX 3	MVA 8 + OX 3B	MVB 12 + OX 5	MVB 12 + OX 5B	MVB 16 + OX 7	MVB 16 + OX 7B	MVC 19 + OX 13	MVC 19 + OX 13B
Line N° 1 without OX HP								
Without air-conditioning	922701	922702	922703	922704	922705	922706	922707	922708
With air-conditioning	922850	922851	922852	922853	922854	922855	922856	922857
Line N° 1 with OX HP 3								
Without air-conditioning	922858	922859	922860	922861	922862	922863	922864	923177
With air-conditioning	922865	922866	922867	922868	922869	922870	922871	923178
Line N° 2								
Without air-conditioning	922992	922993	922994	922995	922996	922997	922998	922999
With air-conditioning	923000	923001	923002	923003	923004	923005	923006	923007
Line N° 3								
Without air-conditioning	923008	923009	923010	923011	923012	923013	923014	923015
With air-conditioning	923016	923017	923018	923019	923020	923021	923022	923023

Optional accessory references

PROCOM 2 extension for generator single line or line N° 1 (when an option is selected)	363171
1 Manual CO / CO ₂ infrared analyser *	724383
Automatic CO / CO ₂ infrared analyser *	724385
2 O ₂ hygrometry monitoring *	823735
3 Wall-mounting analyser: O ₂ / ambient air **	622709
Power consumption monitoring	see page 34
Portable ambient oxygen analyser	622765
Uninterruptible power supply (1 per generator)	624030

* to install on the line N° 1 (of multi-line)

** to install in each container



Specifications are subject to be changed without notice.

OXYGEN CONTAINER

Composite material

Air compartment



PSA oxygen production plants

Oxygen compartment



OXYGEN CONTAINER

Sea container



Air compartment



PSA oxygen production plants



Oxygen compartment



- Lubricated screw compressors 8, 11 and 15 bar
- Ideal efficiency thanks to a specific profile of the screws
- Low electricity consumption with IE3 motor
- Low noise running
- Reduced maintenance
- Possible computerized remote control

Characteristics per compressor

AIRMIL'S G	Power kW 50 Hz	Pressure / Flow rate * 50 Hz (60 Hz)			Noise level ** dB(A)	Weight kg	Dimensions L x D x H mm
		bar / m ³ .h ⁻¹					
MVX2	2.2	8 / 20 (20)	11 / 16 (16)	--	60	140	590 x 632 x 970
MVX3	3	8 / 27 (27)	11 / 22 (22)	15 / 15 (15)	61	140	590 x 632 x 970
MVX4	4	8 / 36 (36)	11 / 29 (29)	15 / 22 (22)	62	145	590 x 632 x 970
MVX5	5.5	8 / 48 (48)	11 / 40 (40)	15 / 32 (32)	64	155	590 x 632 x 970
MVA8	7.5	8 / 72 (72)	11 / 60 (60)	15 / 45 (45)	64	210	630 x 762 x 1100
MVB12	11	8 / 120 (120)	11 / 100 (100)	15 / 78 (78)	64	312	750 x 895 x 1260
MVB16	15	8 / 150 (150)	11 / 126 (130)	15 / 102 (106)	65	320	750 x 895 x 1260
MVC19	22	8 / 210 (204)	11 / 179 (174)	15 / 150 (144)	67	505	800 x 1110 x 1530
MVC23	22	8 / 243 (240)	11 / 210 (207)	15 / 174 (170)	69	525	800 x 1110 x 1530
MVD31	30	8.5 / 332 (326)	12 / 269 (274)	15 / 223 (214)	69	750	1460 x 900 x 1530
MVE38	37	8.5 / 420 (403)	12 / 336 (326)	15 / 266 (271)	70	985	1590 x 1030 x 1700
MVE46	45	8.5 / 489 (495)	12 / 411 (395)	15 / 328 (320)	71	1060	1590 x 1030 x 1700
MVF55	55	8 / 606 (600)	11 / 492 (498)	15 / 396 (390)	69	1300	1650 x 1041 x 1865

* Compressor flow rate further to ISO 1217 : 1996 - C Annex

** Noise level further to PN8 NTC 2.3, measured one away meter in free area.

Process sequence

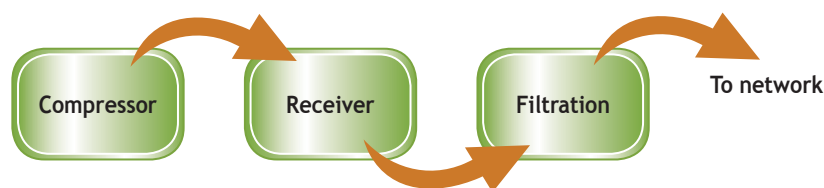

Standard power supplies

- 3-phase, 400V/50Hz + N or 460V/60Hz + N
- 3-phase, 380V/60Hz
- Other tensions on request

Available set-up

	AIRMIL'S G 1 production assembly	AIRMIL'S G 2 production assemblies
Independent	■	○
MILLENIUM	○	■
CYCLIC 2020	◆	◆
Hygrometry sensor	◆	◆
Pressure regulator	◆	◆
Air treatment device	◆	◆
Regulation receiver	◆	◆
Oil-water separator	◆	◆

■ standard equipment ◆ optional equipment ○ non available

Specifications are subject to be changed without notice.



Range complying with
97/23/CE directive

Lubricated screw compressor



Screw compressor AIRMIL'S G plant references

AIRMIL'S G	Independent compressor			Remote driven compressor			
	8 bar	11 bar	15 bar	8 bar	11 bar	11 bar	15 bar
	3-ph 400V/50Hz	3-ph 400V/50Hz	3-ph 400V/50Hz	3-ph 400V/50Hz	3-ph 400V/50Hz	3-ph 380V/60Hz	3-ph 400V/50Hz
MVX2	413229	413233	--	821456	821457	824048	---
MVX3	413230	413234	413237	821459	821460	823809	821461
MVX4	413231	413235	413238	819006	819018	823800	819030
MVX5	413232	413236	413239	821462	821463	824049	821464
MVA8	413155	413153	413151	819008	819020	821412	819032
MVB12	413442	413443	413444	823517	823518	823770	823519
MVB16	413445	413446	413447	823520	823521	823758	823522
MVC19	413648	413649	413650	823977	823978	824050	823979
MVC23	413619	413620	413621	823927	823928	823772	823929
MVD31	413625	413626	413627	823930	823931	823916	823932
MVE38	413628	413629	413630	823933	823934	824051	823935
MVE46	413631	413632	413633	823936	823937	824052	923938
MVF55	413137	413149	413010	819017	819029	824053	819041

Accessory and option references for AIRMIL'S G

1 CYCLIC 2020 (1-ph 230V)	1 comp. : 824006	2 comp. : 824007	3 comp. : 824008
MILLENIUM (1-ph 230V)	(control of 2 compressors) 716402		
2 Built-in hygrometry sensor	with CYCLIC 2020 715745		
Built-in hygrometry sensor	with MILLENIUM 715810		
3 Oil-water separator	See page 34		
Equipped air receiver	See page 8		
Air treatment device	See page 24		
Network alarm CZA alarm sensor	with CYCLIC 2020 : 613064		with MILLENIUM : 616949
Exhaust hose (1 per compressor)	1/2" - 1 m 723895 for MVX and MVA8	3/4" - 1 m 723896 for MVB	1" - 1 m 723897 for MVC 1 1/4" - 1.5 m 723898 for MVD, MVE and MVF



Screw compressors

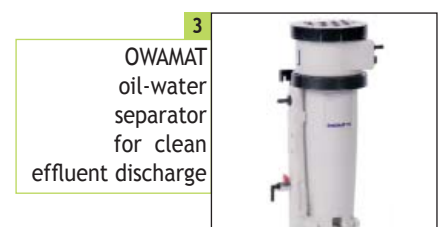
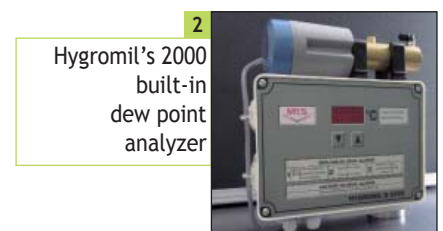

Specifications are subject to be changed without notice.

SEC F to SEC 3F

Air treatment by filtration and drying by refrigeration

- Dew point at -21°C for delivery air (+3°C at 7 bar)
- Permissible maximum pressure: 16 bar
- Cooling gas : R 134 A
- Power supply 230V / 50Hz, 1-ph.

Different filter types

- PF : 1 µm micronic filtration
- CHA : active carbon filter for odour elimination
- PAR : 0.01 µm particles filtration

SEC 2F



Process sequence

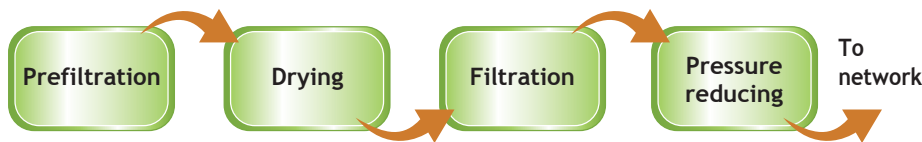

Air quality complying with ISO 8573-1 Standard

TYPE	QUALITY CLASS
SEC 1F	2, 4, 3
SEC 2F	1, 4, 2
SEC 3F	1, 4, 1

Air treatment devices and replacement parts references

Refrigeration air dryer type	ASF 036	ASF 054	ASF 072	ASF 144	ASF 240	ASF 300	ASF 360	ASF 570	
Flow rate at 7 bar in Nm ³ .h ⁻¹ SEC F	36	54	72	144	240	300	360	570	
Flow rate at 7 bar in Nm ³ .h ⁻¹ SEC 1F/2F/3F	36	54	72	108	216	300	360	570	
Absorbed power in Watt	170	250	260	570	710	850	1005	1390	
Inlet	SEC F	F1/2"	F1/2"	F1/2"	F3/4"	F1"1/2"	F1"1/2"	F1"1/2"	
	SEC 1F/2F/3F	F3/8"	F1/2"	F1/2"	F3/4"	F1"	F1"1/4"	F1"1/2"	
Outlet	SEC F / 1F	F1/2"	F1/2"	F1/2"	F3/4"	F1"1/2"	F1"1/2"	F1"1/2"	
	SEC 2F / 3F	F3/8"	F1/2"	F1/2"	F3/4"	F1"	F1"1/4"	F1"1/2"	
SEC F	805884	805885	805889	805890	805891	805892	812296	805894	
SEC 1F Residual oil content 0.5 ppm	upstream	PF36 - ASF036	PF72 - ASF054	PF72 - ASF072	PF109 - ASF144	PF217 - ASF240	PF396 - ASF300	PF396 - ASF360	PF576 - ASF570
	downstream	820662	820663	820664	820665	820666	820667	820668	820669
SEC 2F Residual oil content 0.01 ppm	upstream	PF36 - ASF036	PF72 - ASF054	PF72 - ASF072	PF109 - ASF144	PF217 - ASF240	PF396 - ASF300	PF396 - ASF360	PF576 - ASF570
	downstream	PAR36	PAR72	PAR72	PAR109	PAR217	PAR396	PAR396	PAR576
	820670	820671	820672	820673	820674	820675	820676	820677	
SEC 3F Residual oil content 0.003 ppm	upstream	PF36 - ASF036	PF72 - ASF054	PF72 - ASF072	PF109 - ASF144	PF217 - ASF240	PF396 - ASF300	PF396 - ASF360	PF576 - ASF570
	downstream	CHA36 - PAR36	CHA72 - PAR72	CHA72 - PAR72	CHA109 - PAR109	CHA217 - PAR217	CHA396 - PAR396	CHA396 - PAR396	CHA576 - PAR576
	820678	820679	820680	820681	820682	820683	820684	820685	
Cartridge for replacement PF 1 µm	PF36 430031	PF72 430032		PF109 430033	PF217 430034		PF396 430035	PF576 430036	
Cartridge for replacement CHA Carbon	CHA36 430087	CHA72 430085		CHA109 430088	CHA217 430086		CHA396 430089	CHA576 430065	
Cartridge for replacement PAR particles	PAR36 430049	PAR72 430050		PAR109 430051	PAR217 430052		PAR396 430053	PAR576 430054	

Accessory and option references

1 COMBI automatic drain	under PF/SUB filters (1-ph 230V)	620721
2 BEKO 12 electronic drain	under PF/SUB filters (1-ph 230V)	615160

Dimensions (mm)

Combination

ASF036 to ASF360

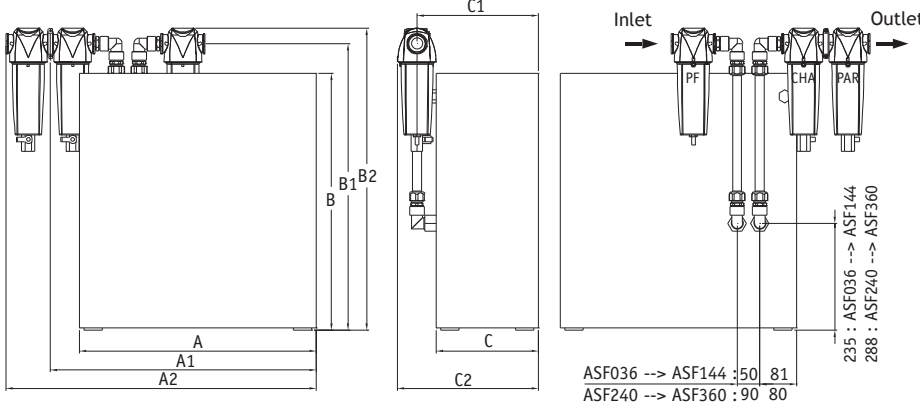

TYPE	PF	F DRYER	CHA	PAR
SEC F		■		
SEC 1F	■	■		
SEC 2F	■	■		■
SEC 3F	■	■	■	■

ASF570

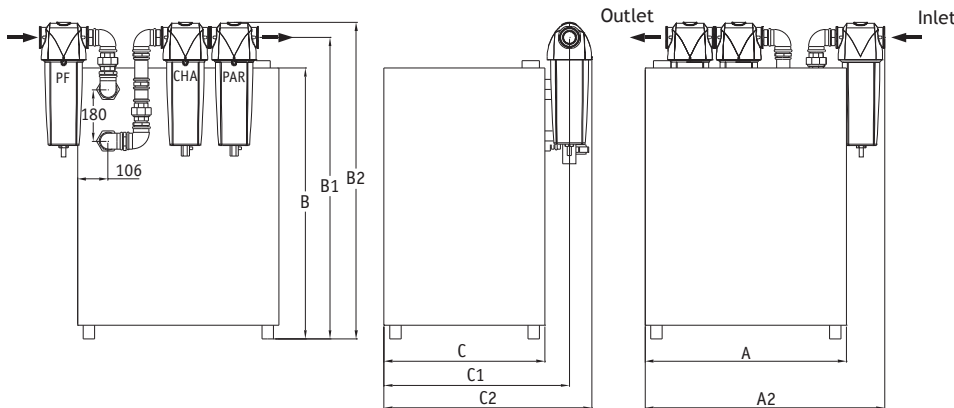

DRYER TYPE	For SEC F/1F/2F/3F versions							for SEC 2F version	for SEC 3F version	for SEC F version	for SEC 1F version		for SEC 2F/3F versions		Weight (kg)			
	A	B	B1	B2	C	C1	C2	A1	A2	∅ Inlet ∅ Outlet	∅ Inlet	∅ Outlet	∅ Inlet ∅ Outlet	∅ Inlet ∅ Outlet	SEC F version	SEC 1F version	SEC 2F version	SEC 3F version
ASF036	450	430	466	494	210	254	287	483	559	F1/2"	F3/8"	F1/2"	F3/8"	19	20	21	22	
ASF054	500	505	545	580	210	254	297	560	657	F1/2"	F1/2"	F1/2"	F1/2"	24	25.5	27	28.5	
ASF072	500	505	545	580	210	254	297	560	657	F1/2"	F1/2"	F1/2"	F1/2"	24	25.5	27	28.5	
ASF144	520	565	630	664	225	268	310	585	682	F3/4"	F3/4"	F3/4"	F3/4"	31	32	34	36	
ASF240	555	604	676	718	425	500	557	668	797	F1"1/2"	F1"	F1"1/2"	F1"	52	55	58	60	
ASF300	555	604	676	718	425	500	557	668	797	F1"1/2"	F1"1/4"	F1"1/2"	F1"1/4"	58	62	66	69	
ASF360	555	604	676	718	425	500	557	668	797	F1"1/2"	F1"1/4"	F1"1/2"	F1"1/4"	60	64	68	71	
ASF570	703	945	1052	1105	562	647	725	---	837	F1"1/2"	F1"1/2"	F1"1/2"	F1"1/2"	83	89	95	100	

Correction table for capacities according to the operating pressure	operating pressure in bar	2	4	6	7	8	10	12	14	16
	multiplying factor	0.53	0.76	0.93	1	1.07	1.19	1.31	1.41	1.51



1
COMBI
automatic drain
fitted on the filter



2
BEKO12
electronic drain
fitted on the filter

Specifications are subject to be changed without notice.

Oxygen high pressure cylinder filling station

- Oil-free piston booster(s) driven by compressed air
- Multi-stage compression
- Simple and robust compression technology
- No pollution of O₂ during compression
- Low maintenance requirements
- PROCOM 2 regulation device
- Supply with pressure release line at 4 bar or 7 bar on the O₂ network
- Possible association with filling skid design for gas cylinders
- Maximum pressure : 200 bar



Oxygen high pressure cylinder rack
12 x B50

Process sequence

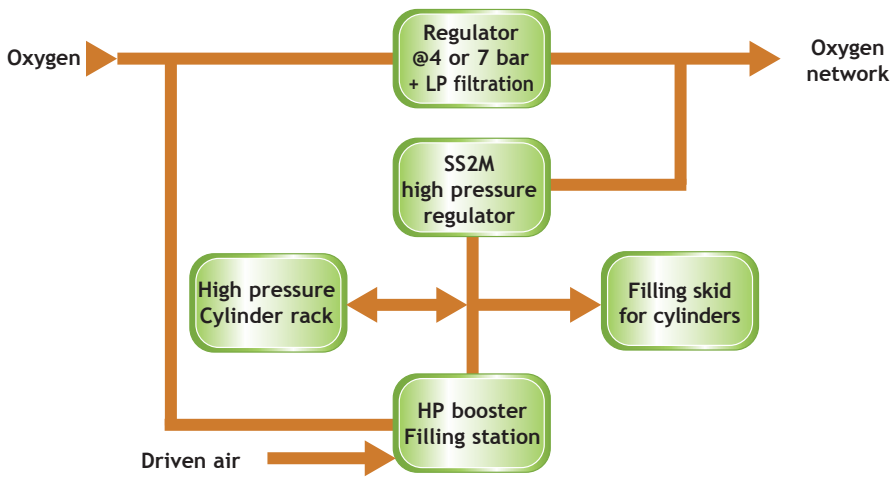

Standard power supply

- 1-phase, 230V - 50 / 60 Hz

Characteristics

	OX HP 3		OX HP 6		OX HP 12		
Number of boosters	1		2		3		
Number of compression stages	2		3		3		
O ₂ inlet pressure	bar	4	5	4	5	4	5
O ₂ inlet average flow rate	(Nm ³ /h)	3.3	3.9	6.2	7.1	12.4	14.2
O ₂ outlet average flow rate	(Nm ³ /h)	2.6	3	5.2	6.1	10.5	12.1
B50 at 180 bar filling time	(minutes)	212	180	105	89	53	45
Motor air maximum capacity	(Nm ³ /h)	70	72	140	142	165	169

(mm)	L	P	H	Weight
6 x B50	530	760	1790	460 kg
9 x B50	790	800	1880	720 kg
12 X B50	780	1000	1880	900 kg
20 x B50	1060	1360	1880	1550 kg

Optional accessory references

	6 x B50 722974	9 x B50 722975	12 x B50 722976	20 x B50 722977
Oxygen high pressure cylinder rack				
Cylinder rack connection hose	722978 (F type / 3 m)			
Copper connection for cylinder rack	332930 (F type / 3 m)			
Cylinder + valve + guard	B5 723874	B20 723889		B50 722979
Cylinder connection hose	362087 (type F / 1,5 m)			
Copper connection cylinder	363147 (type F / 1,5 m)			



O₂ cylinder filling and supply system reference

	OX HP 3
SS2M - backup 4 bar + network connection 5 bar	923851
SS2M - backup 7 bar + simple pressure release line	923852
SS2M - backup 7 bar + duplex pressure release line	923853

Dimensions (mm)

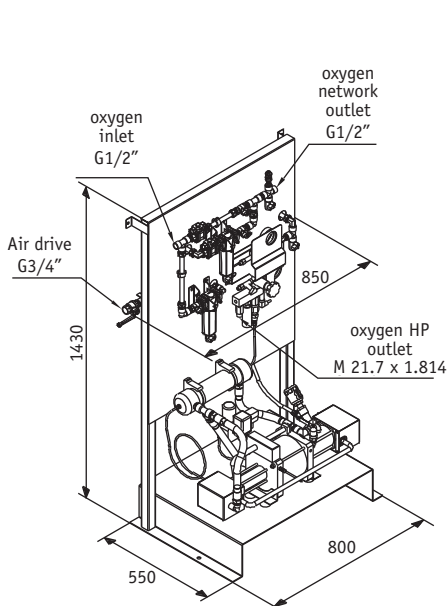

OX HP 3 - oxygen high pressure cylinder filling station with connection to 5 bar network

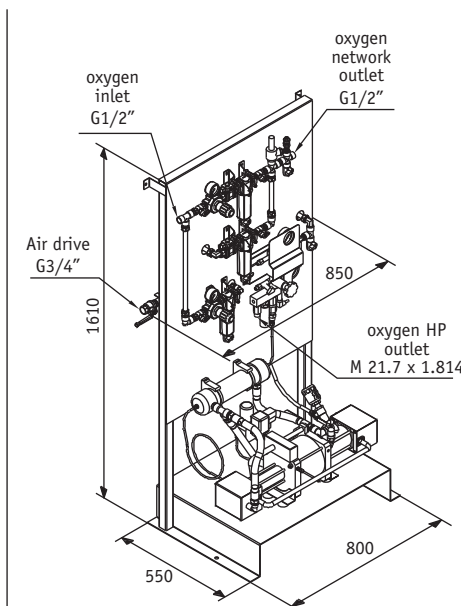

OX HP 3 - oxygen high pressure cylinder filling station with simple pressure release line

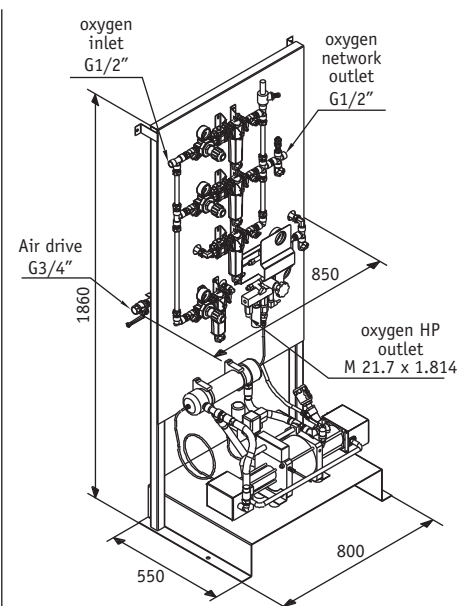

OX HP 3 - oxygen high pressure cylinder filling station with duplex pressure release line

OX HP 6 / OX HP 12



OX HP 6 / OX HP 12



Inside OX HP 12

O₂ cylinder filling and supply system reference

	OX HP 6
SS2M - backup 4 bar + network connection 5 bar	923709 + 823761
SS2M - backup 7 bar + simple pressure release line	923709 + 823762
SS2M - backup 7 bar + duplex pressure release line	923709 + 823763

	OX HP 12
SS2M - backup 4 bar + network connection 5 bar	923708 + 823761
SS2M - backup 7 bar + simple pressure release line	923708 + 823762
SS2M - backup 7 bar + duplex pressure release line	923708 + 823763

Dimensions (mm)

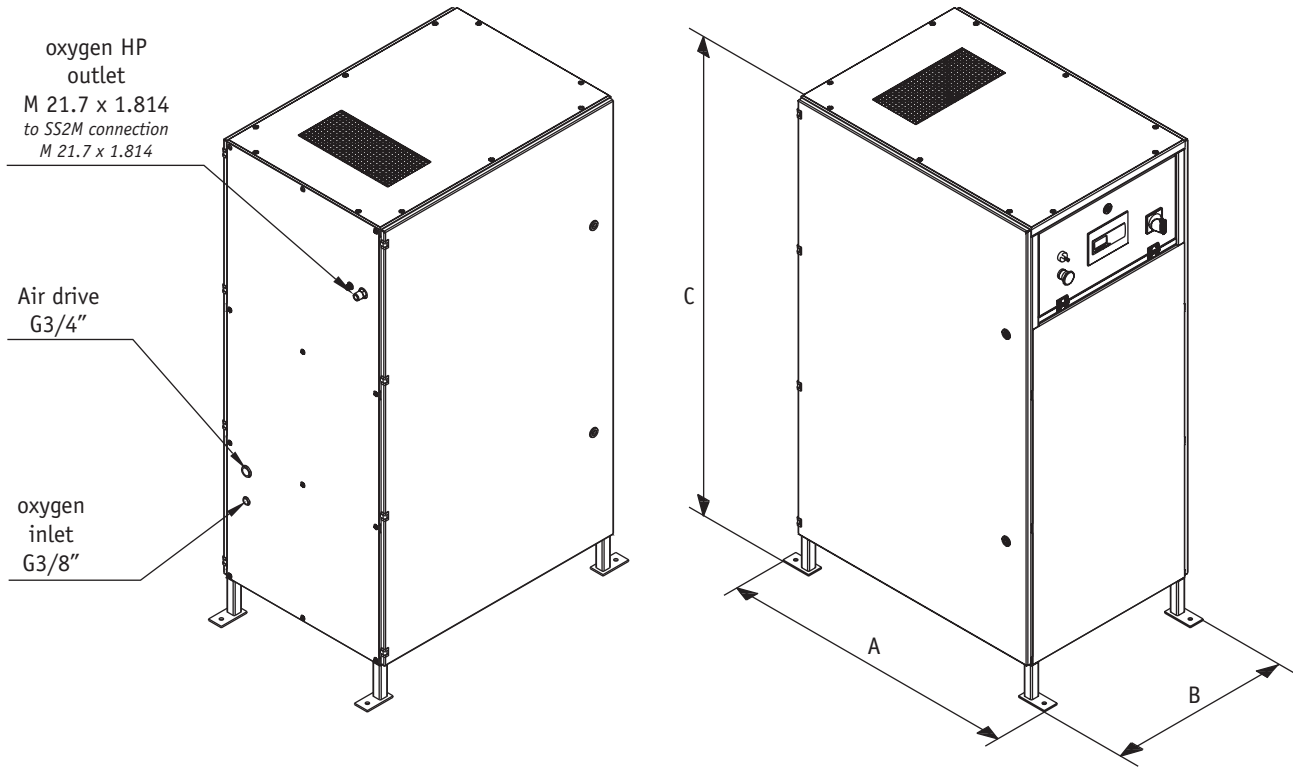

	OX HP 6	OX HP 12
A	1020	1020
B	620	620
C	1300	1600

High pressure / low pressure regulators : SS2M assembly dimensions (mm)

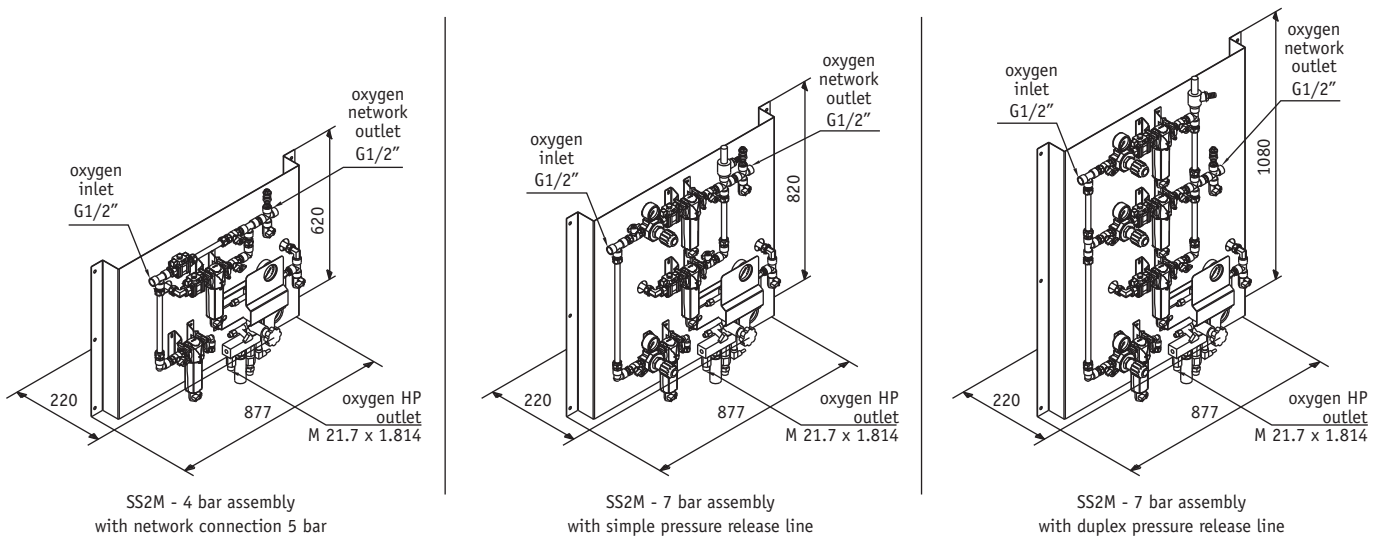

Filling skid for 8 gas cylinders

- Filling skid for 1 to 8 gas cylinders - Maximum working pressure 200 bar
- 8 adjustable positions: 8 x B50 type, 2 x B15/B20 type, 2 x B5 type - type F
- Before filling operation, proceed to cylinder cleaning process using a special vacuum pump EVISA design for O₂ (flow rate 40 m³/h)
- Equipment connected (dia.6) to a high pressure compression system

Standard power supply

- 1-phase, 230V - 50 / 60 Hz

Dimensions (mm)

- 1930 (H) x 730 (W) x 1802 (D)

Reference

Filling skid for 8 gas cylinders

723112



Filling skid for 8 gas cylinders



EVISA E40 oxygen special type



High pressure hose connected to the cylinder



Plug base

Control and regulation device

PROCOM 2

- Up-to-date technology, PROCOM 2 touch-screen computer brings a big change in human/machine interaction. It perfectly matches the running of a oxygen production plant equipped with oxygen generators, automatic compressed air plants and air treatment units.
- Remote monitoring with RS485/Modbus or Ethernet.
- USB key for data gathering : curves, parameters and events.



Available curves :

- Oxygen concentration,
- Air or regulation or network pressure,
- Cylinder pressure,
- CO or CO₂ or ambient O₂ content,
- Oxygen hygrometry and air hygrometry

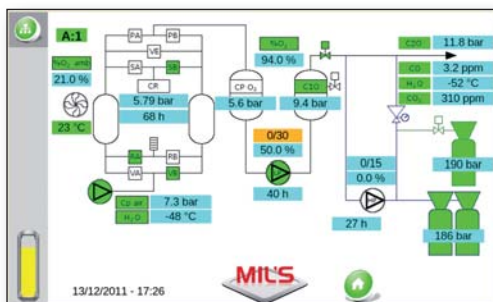

Synoptic screen to match in a wink the complete running of the oxygen production plant

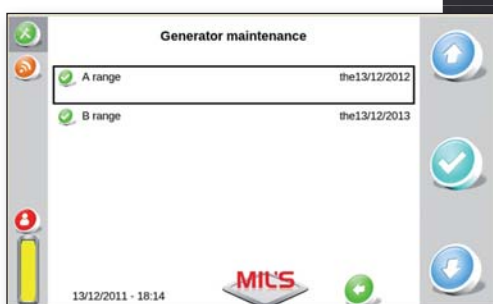

Management of the maintenance schedule of the generators, the compressors, the dryers and the oxygen sensor.



Screen display for alarm, regulation and maintenance events



Summary of existing alarms

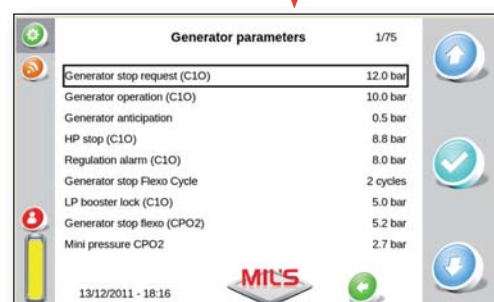

Many possibilities to customize the oxygen production plant running

MIL'S Regulation

Monitoring system for medical fluids

Vigifluid

- Supervision system for monitoring the operation of the MIL'S oxygen plants controlled by PROCOM 2.

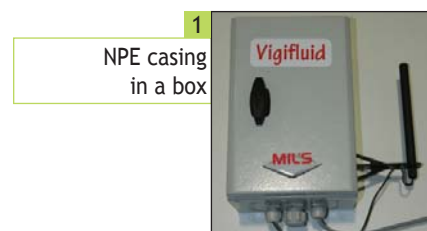
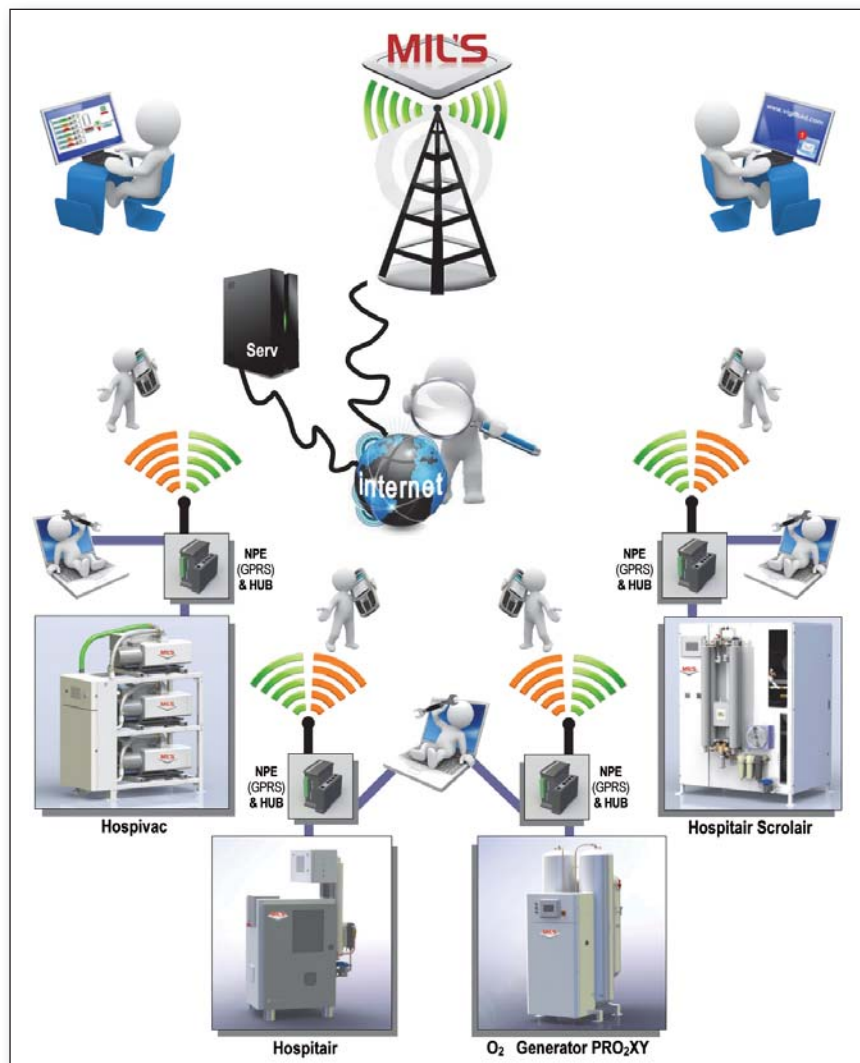

Communication interface including built-in GPRS for	One PROCOM 2	Two PROCOM 2
1 NPE casing fitted in a remote box (H: 300, W: 200, P: 150) to collect GPRS signal + 30 meters of RJ45 cable + Programming of the Vigifluid website	624213	624507
2 30 meters of RJ45 cable (a maximum total length of 90 meters = 3 x 30 meters maxi)	624214	

Vigifluid subscription for a year

Data storage and archiving on secure server + MIL'S remote support for the breakdown diagnostic	624215
---	--------

Energy monitoring

- Measuring continuously voltage (3-phase), current and power consumption.
- Voltage of the three phases measurement.
- Two-wire current measurement.
- Power supply : 24Vdc.
- Output signal : RS485 / Modbus (connection to PROCOM 2).
- Size : 50 A or 100 A.
- Alarm monitoring on high voltage, low voltage and overcurrent.

Energy transmitter



Current measurement

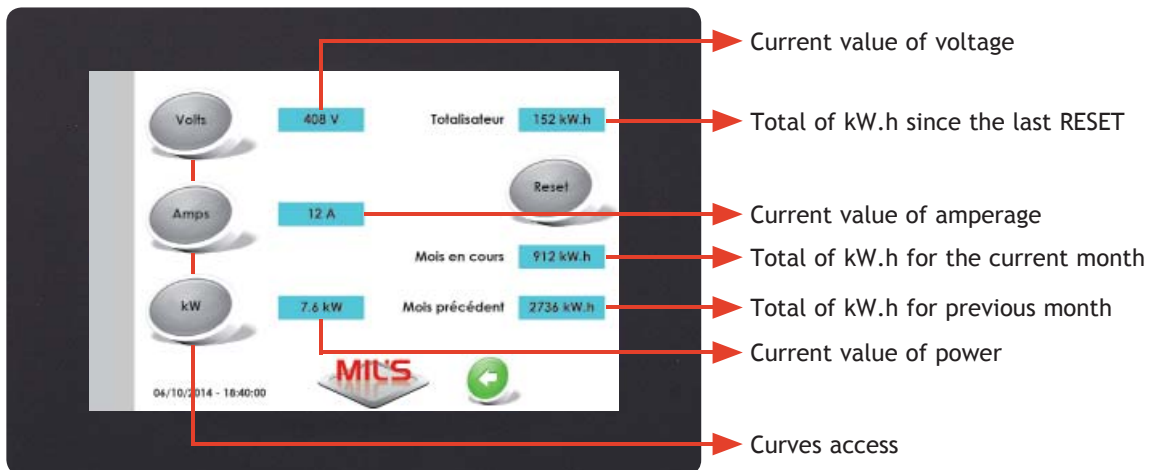

References

	Size	
	50 A	100 A
Energy monitoring	622956	624726

Note : In the case of several motors to be supervised, the energy monitoring must be placed upstream distribution.

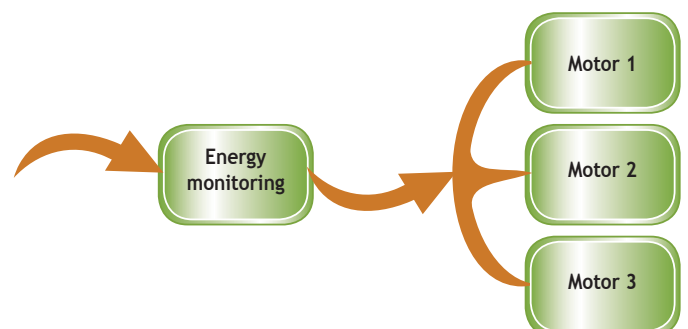

Services

Main office



MIL'S, aware of your imperatives and requirements, offers all kind of services to enhance the use you make of your equipments.

Training



Training

Compose your program from the numerous available modules, whether theoretical or practical, on air, on vacuum, on oxygen and of course, the standard and regulated environments for our products.

After-sales service



After-Sales Service

From intervention on your premises to servicing in our factories, from troubleshooting to maintenance contract, our technicians will help you to maintain the performance of your equipment and will advise you on their optimisation.

Useful formulae

Flow rate calculation further to altitude

The after-specified formula allows to calculate the pressure further to the altitude.
Mind, this formula is valid up to 50 km altitude.

$$p = 1013 e^{-h / 7,5}$$

with : p : pressure in hPa
h : altitude in km

	Altitude (km)	Pressure (hPa)
At sea level	0	1013
At Mont Blanc mountaintop	4,8	560
At Everest mountaintop	8,8	320
At average plane flight altitude	15	120

Dew point conversion chart

This chart allows to convert a dew point expressed at atmospheric pressure into a dew point at compressed air pressure

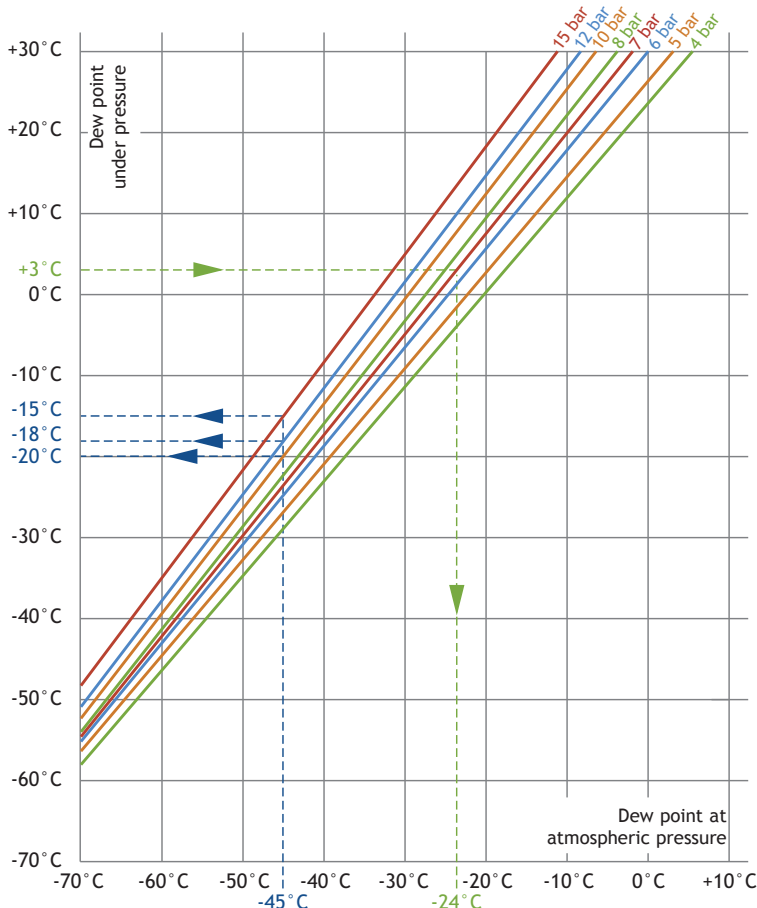

Conversion tables

Vacuum / Pressure

1 mbar	= 0,0295 in Hg
1 bar	= 14,50 psi
1 kPa	= 10 mbar = 0,01 bar

Dimensions

1 mm	= 0,039 in
1 m	= 3,281 ft = 39,37 in

Power

1 kW	= 1,341 hp
------	------------

Weight

1 kg	= 2,205 lb
------	------------

Flow rate

1 m ³ .h ⁻¹	= 16,667 L.min ⁻¹ = 0,5886 cfm
1 L.min ⁻¹	= 0,2642 gal.min ⁻¹

Temperature

t(°F)	= 1,8 x t(°C) + 32
-------	--------------------

Water vapour pressure

The following board gives vapour pressure at water level for temperatures included between 0 and 100 ° C

Temperature °C	Pressure mbar
0	6,11
5	8,72
10	12,28
15	17,05
20	23,38
25	31,67
30	42,43
35	56,23
40	73,77
45	95,84
50	123,35
55	157,39
60	199,17
65	250,05
70	311,60
75	385,47
80	473,47
85	578,13
90	701,01
95	845,20
100	1013,33

Specifications are subject to be changed without notice.

Useful formulae

Dew point: definition

Temperature of a cold wall plunged into a humid chamber at which the condensation of humidity present in air appears.

Air humidity

Values indicated in the table hereafter correspond to dew points i.e. to the weights of saturating water vapour per m³ beyond which water condenses into a liquid at the considered temperature.

Dew point °C	ppm (volume) in air	ppm (weight) in air	Partial vapour tension mg/m ³	Relative humidity at 21 °C %
- 84	0,263	0,16	0,189	0,00107
- 82	0,382	2,24	0,288	0,00155
-80	0,526	0,33	0,399	0,00214
-78	0,737	0,46	0,558	0,00300
- 76	1,01	0,63	0,765	0,00412
- 74	1,38	0,82	1,040	0,00562
- 72	1,88	1,17	1,420	0,00765
- 70	2,55	1,64	1,930	0,0104
- 68	3,43	2,13	2,60	0,0140
- 66	4,59	2,84	3,48	0,0187
- 64	6,10	3,71	4,61	0,0248
- 62	8,07	5,01	6,15	0,0328
- 60	10,8	6,59	8,00	0,0433
- 58	13,9	8,21	10,6	0,0567
- 56	18,2	11,6	13,8	0,0738
- 54	23,4	14,5	17,8	0,0952
- 52	30,2	18,8	23,0	0,126
- 50	38,8	24,2	29,5	0,160
- 48	49,7	30,7	37,8	0,202
- 46	63,2	39,3	48	0,257
- 45	67	44,5	54,5	0,291
- 42	101	61,7	77	0,410
- 40	127	79,1	97	0,516
- 38	159	98,6	122	0,646
- 36	197	123	151	0,804
- 34	246	156	188	1,01
- 32	305	189	232	1,24
- 30	376	234	288	1,55
- 28	462	287	352	1,88
- 26	566	351	430	2,30
- 24	692	431	527	2,81
- 22	842	524	640	3,42
- 20	1021	635	790	4,14
- 18	1236	766	940	5,01
- 16	1489	925	1140	6,06
- 14	1791	1110	1360	7,29
- 12	2147	1340	1640	8,75
- 10	2566	1590	1950	10,40
- 8	3061	1900	2300	12,8
- 6	3638	2260	2780	14,8
- 4	4316	2680	3300	17,5
- 2	5105	3170	3900	20,7
0	6025	3800	4600	24,1

General conditions of sale and guarantee - Sales contract

GENERAL POINTS

The orders noted and the commitments taken by the Representatives or Agents, are only binding on Company MIL'S after WRITTEN ACCEPTANCE.

The orders only become final after forwarding of an acknowledgment of receipt. They imply the acceptance of the present general conditions of sale notwithstanding any contrary clauses of our customers that have not been expressly accepted in writing.

The role of our company consists in manufacturing the equipment. It is not for it to appreciate the appropriateness of the choice of any equipment as regards its final destination or the use to which it is allocated.

Any information that we may be led to provide is only given in the framework of our productions and for information, and does not consist of indications regarding the choice of the equipment or the final use for which it is destined. In no case can our liability be incurred if there is no sale of equipment.

Our activity consists in manufacturing products ordered by our customers and it is not for us to appreciate the appropriateness of an order for the use to which it is destined by the purchaser.

The present general conditions and the special conditions insofar as the latter are not contrary to the present general conditions and still comply with general contract law and competition law can be completed by Company MIL'S general conditions of purchase expressly accepted by the Supplier. It is the responsibility of the Customer to ensure compliance with local regulatory requirements.

Any derogation to the present general conditions is subject to our express and written acceptance.

TRANSFER OF OWNERSHIP - RESERVATION OF OWNERSHIP TRANSFER OF RISK

The merchandise shall remain our property up until the full payment of its price in principal and interest. Failing the payment of the price on the agreed due date, we shall be able to take back the merchandise, the sale being declared void if this seems proper to us, and the deposits already paid shall remain acquired by us in return for the enjoyment of the merchandise from which the Customer will have benefited.

The Customer becomes responsible for the merchandise as soon as it is collected from our factory, the transfer of possession leading to the transfer of risks. The Purchaser undertakes, consequently, to take out, as of now, an insurance contract covering the risks of loss, theft or destruction of the merchandise.

INTELLECTUAL PROPERTY AND KNOW-HOW FOR DOCUMENTS AND PRODUCTS

All intellectual property rights as well as know-how incorporated into forwarded documents, delivered products and provided services shall remain the exclusive property of Company Mil's.

STUDIES AND PROJECTS

The studies and documents of any nature passed on or sent remain entirely our property. They cannot lead to communication or to execution by a third party.

CANCELLATION OF A CONFIRMED ORDER

The cancellation or termination of an order, instigated by the customer, in the course of execution for a cause outside our control, including force majeure, shall render the customer the debtor in respect to Company Mil's of compensation that, in no case, shall be less than 20% of the amount of the order and also less than the amounts of purchases and time already spent and this, whatever be the state of play, and furthermore any deposit already paid shall be kept as cover.

RETURNS

No merchandise can be returned to Company Mil's without the agreement of the latter.

DELIVERY AND PRICE

THE DELIVERY IS DEEMED MADE IN OUR FACTORIES OR STORES. It is made by the direct handing-over to the Customer, by simple notice of availability, or by handing-over to a shipper or to a carrier appointed by the Customer or, failing such appointment, chosen by us.

In accordance with agreement between the Parties at the time order.

The delivery times are given for information and are not guaranteed. Delivery delays do not give the Customer the right to cancel the sale or to refuse the merchandise. They cannot give rise to retention, compensation, penalty or damages.

THE PRICES ARE UNDERSTOOD TO EXCLUDE TAX FOR THE EQUIPMENT NOT PACKED TAKEN IN OUR FACTORIES OR STORES, THOSE PRICES ARE IN EUROS.

CONDITIONS OF USE

All equipment is delivered accompanied by technical instructions that we recommend should be followed. If these instructions are not attached, they will be immediately forwarded on simple request.

Company MIL'S may on no account be held responsible in case of installation by third party, improper or not compliant with Company MIL'S recommendations in the technical notice, neither in case of improper use of the material regarding instruction given in this technical notice. Company MIL'S reserves the right to modify technical specifications at any time and without notice of its manufactured materials.

PAYMENT CONDITION

In case of no negotiation before ordering, the payment term is by swift transfer, within eight days, at reception of invoice, with minimum of 60 € net. (Payments are made in euros unless otherwise stipulated in the agreement).

It is expressly agreed and failing timely request for postponement and granted by us, the failure to pay our invoices after the deadline indicated on the said invoices, shall lead to:

1. the immediate payability on the amounts remaining due,
2. the interests calculated at a rate equal to 15% per year and any legal costs.
3. in accordance to the law n° 2012-387 dated 22/03/2012 and to the modification of L 441-3 article of Commerce Code: "for any payment effected after the deadline, a penalty charge will be legally due, for recovery costs, to the creditor. The amount of this charge is stated at 40 € by the Decree dated 02/10/2012."

We do not grant discount for early payment, unless it has been negotiated at the time of the order.

Notification of the Customer situation:

In case the deterioration of the Customer situation is noticed by any means and/or certified by a significant delay in payment or when the financial situation is appreciably different from the available data, the delivery will be made only in compensation for an immediate payment.

TRANSPORT

All transport operations, insurance, customs, handling carried out ARE PAYABLE BY AND AT THE RISKS OF THE CUSTOMER who is responsible for checking the shipments on arrival and for taking action, if appropriate, against the carriers.

In the case of dispatch ensured by us, this shall be made carriage due, full responsibility resting with the Customer.

GUARANTEE OF THE EQUIPMENT

Except the cases of legal guarantee that one cannot be interfered with, OUR MERCHANDISE IS GUARANTEED ONE YEAR, as from the date IT IS MADE AVAILABLE, against any construction defect or any fault in the material.

In all cases, if the equipment is used by several teams, the period of the guarantee is necessarily reduced by half. For the components that are not of our manufacture, we are not substituted in the conditions of guarantee of the supplier constructor.

The guarantee does not apply to replacements or to repairs that could result from normal wear of the instruments, deterioration or accidents due to a defect in surveillance or installation and improper use. Likewise are excluded from the field of application of the guarantee, deteriorations resulting from damage during transport, falls, or violent shocks.

The guarantee is limited to the free replacement, in our workshops, of the machine pieces or parts recognised as defective due to material fault or manufacturing defect, with the exclusion of labour.

The transport costs, the outward as the return journey, are to be paid by the Customer.

The guarantee ceases if the instruments are modified or repaired outside our workshops. The passage through our workshops does not lead to the extension of the period of initial guarantee of the machine. Replacement parts or remade pieces are guaranteed 6 months, as from the delivery date after our intervention. The guarantee shall not apply in the event of non-payment by the Customer and he cannot take advantage of it or postpone his payments.

LOAN OF EQUIPMENT

Company MIL'S may have to lend some material for a determined duration under conditions defined in a loan contract. At the end of the agreed period, the Customer shall notify if the material on loan will be returned or ordered.

In the absence of any notification within this period, the sale shall be deemed to be effective, as the Customer will be presumed to have accepted the delivered product.

ELIMINATION OF WASTE

"In accordance with article 18 of the decree N° 2005-829 of July 20th, 2005 relating to the composition of the electrical and electronic equipment, the Customer will be responsible for the financing and organisation of the elimination of waste from this equipment under the conditions defined in articles 21 and 22 of the said decree. In case of control, Company MIL'S may ask his Customer to send him the documents establishing he fulfils, as regard this equipment, all the obligations transferred with the sales contract. If the Customer fails to forward these documents, he will be presumed to be liable for non-fulfilment of the obligations he is responsible for and Company MIL'S reserves the right to ask him compensation for any damage that she could suffer thereby".

INSURANCE COVERING OUR LIABILITY

Our company has taken out an insurance policy covering the pecuniary consequences of our legal liability and this in the following way:

Civil Liability for Operations: € 10,000,000 per claim, all physical injury, and tangible and intangible losses inclusive, with:

- € 2,500,000 for "inexcusable conduct" per claim and per year of insurance.
- € 500,000 for physical injury and for tangible and intangible losses resulting from pollution, per claim and per year of insurance.
- € 5,000,000 for tangible and intangible losses other than from pollution, per claim and with the following sub-limits:
 - € 300,000 for non-consecutive intangible losses per claim.
 - € 100,000 for tangible losses pertaining to property of others and consequential intangible losses, per claim.
 - € 30,000 for theft by a servant or agent per claim.

Civil Liability for Delivered Products/ Product recalls:

€ 3,000,000, all physical injury, tangible and intangible losses inclusive, per claim and per year of insurance, with: €500,000 for non-consecutive intangible losses including removal/reinstallation expenses engaged by third parties, per claim and per year of insurance.
€ 300,000 forrecal costs engaged by third parties and by the policy holder, per claim and per year of insurance.

Company MIL'S responsibility will not be engaged for amounts exceeding the guaranteed amounts, which is expressly agreed by the Customer. Company MIL'S may (if applicable) be lead to subscribe complementary guarantee, on Customer's specific request and Customer's sole expense: he will exclusively assume the costs.

DISPUTES

In the case of disagreement relating to a delivery or its payment, the Lyon Commercial Court is the sole competent, whatever may be the sales conditions and the method of payment chosen, even in the case of proceedings against the guarantor or more than one defendant. The applicable law, regarding the seller and the buyer respective obligations, is the French law.

SPECIAL CONDITIONS

The special conditions and those that may be indicated in the documentations, quotes or prices forwarded only modify the sales conditions on the precise points to which they relate.

VIGILANCE system

The Customer must put forward, without any delay, to the vigilance system correspondent complete information about any incident, real or potential (further to decree 96/32 definition), involving a medical device provided by Company MIL'S. The Customer, if necessary, will have to cooperate in the implementation of all warning measures.

TRACEABILITY

The Customer must ensure the maintenance of traceability of all the medical devices delivered by MIL'S, including devices by their own customers and dealers, in order that the information concerning a product can be obtain, at any time on Company MIL'S or any competent authorities' requirement. In accordance with 93/42/CEE directive, the records referring to traceability have to be kept, at least during the device life and anyway during five years.

MODIFICATION OF GENERAL CONDITIONS OF SALES AND GUARANTEE

The seller reserves the right to modify, at any time, the herein general conditions of sales and guarantee and, in such case, the modified conditions will apply to any order set after the modification date, this, even for complementary or supplementary orders referring to previous operations.

09/14

15 rue de Genève - 69746 Genas - France
tél. 33 (0)4 7278 00 40 - fax 33 (0)4 78 00 82 34
www.mils.eu - sales@mils.fr



oxygen